

# Why use charged aerosol detection with inverse gradient?

Authors: Sylvia Grosse<sup>1</sup>, Tibor Muellner<sup>1</sup>,  
Katherine Lovejoy<sup>1</sup>, Ian Acworth<sup>2</sup>,  
Paul Gamache<sup>2</sup>

<sup>1</sup>Thermo Fisher Scientific,  
Germering, Germany

<sup>2</sup>Thermo Fisher Scientific,  
Chelmsford, MA, USA

Keywords: Vanquish Duo for Inverse Gradient,  
charged aerosol detection, universal detector,  
inverse gradient, uniform response, universal  
calibration, single calibrant, increased  
sensitivity

## Goal

Three different approaches for inverse gradient are evaluated, and their advantages and disadvantages discussed regarding uniform response, sensitivity, and their environmental/financial impact.

## Introduction

The charged aerosol detector (CAD) is a universal detector used by all major branches, including pharmaceuticals/biopharmaceuticals, food and beverage, and environmental, for the analysis of both small and

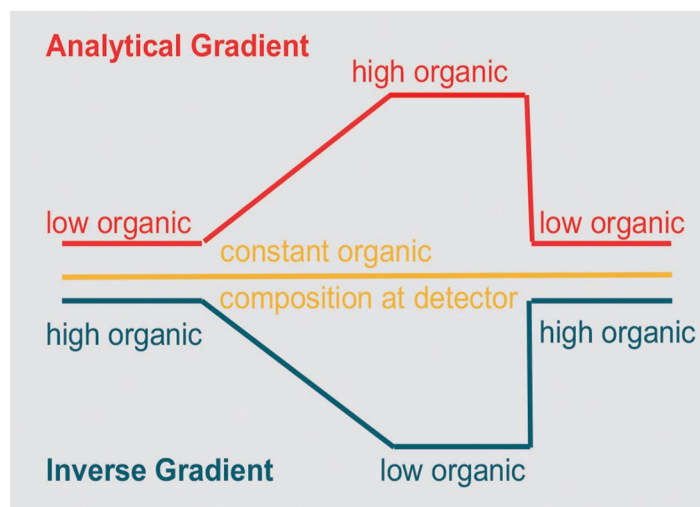

large molecules. The CAD can be used with both high-performance liquid chromatography (HPLC) using a variety of separation chemistries (e.g., reversed-phase (RP), hydrophilic-interaction liquid chromatography (HILIC), mixed-mode techniques, or size exclusion approaches) and supercritical fluid chromatography (SFC),<sup>1</sup> resulting in a high degree of analytical flexibility. Like mass spectrometry (MS), the mobile phases used with the CAD must be volatile. Buffers, such as ammonium formate or ammonium acetate, can be used in combination with the most common HPLC solvents, including acetonitrile, methanol, and isopropanol.

UV absorbance and MS detectors are commonly used to quantify analytes, but the response to these detectors highly depends on the analyte's chromophoric properties or ability to form gas phase ions, respectively. This limits their ability to detect numerous compounds and to provide similar response for a range of analytes. The CAD is a universal detector for non-volatile and semi-volatile analytes that gives uniform response independent of a compound's physico-chemical properties for non-volatiles. Details of various factors that can affect the CAD's uniform response can be found in Technical Note 72806.<sup>2</sup>

In particular, the organic content of the mobile phase entering the detector influences the nebulization process and affects the uniformity of detector response during gradient elution. The effect can be overcome and consistent analyte response restored if mobile phase with constant solvent composition enters the detector. This approach can be achieved by using a second pump to generate a second (inverse) gradient, making the CAD ideal if quantitation is needed and no reference standards are available. With a single calibrant, the quantification of multiple analytes is therefore possible, even in the absence of individual standards, such as during drug discovery.

This technical note explains the advantages and disadvantages of inverse gradient workflows based on three exemplary use cases.

## Experimental

### Chemicals

- Thermo Scientific™ Barnstead™ GenPure™ xCAD Plus Ultrapure Water Purification System, deionized water, 18.2 MΩ·cm at 25 °C (P/N 50136149)
- Fisher Scientific™ Acetonitrile Optima™ LC/MS grade (P/N A955-212)
- Fisher Scientific™ Ammonium acetate, LC/MS grade (P/N A114-50)
- Fisher Scientific™ Bumetanide, Alfa Aesar™, >98% (P/N AAJ6230203)
- Saccharin sodium, cephalexin hydrate, and cortisone were purchased from a reputable vendor.

### Equipment

- Vials (amber, 2 mL), Fisher Scientific (P/N 11545884)
- Snap Cap with Septum (Silicone/PTFE), Fisher Scientific (P/N 10547445)

### Preparation of standards

The compounds investigated in the study are structurally diverse (Figure 1). Individual stock solutions (1.0 mg/mL) were prepared in 90/10 water/acetonitrile (v/v) for saccharin and cephalexin, and in 50/50 water/acetonitrile (v/v) for bumetanide and cortisone. Mixed working solutions at concentrations of 5 µg/mL, 10 µg/mL, 20 µg/mL, 50 µg/mL, and 100 µg/mL were prepared by dilution of the stock solutions with the appropriate volume of 90/10 water/acetonitrile (v/v).

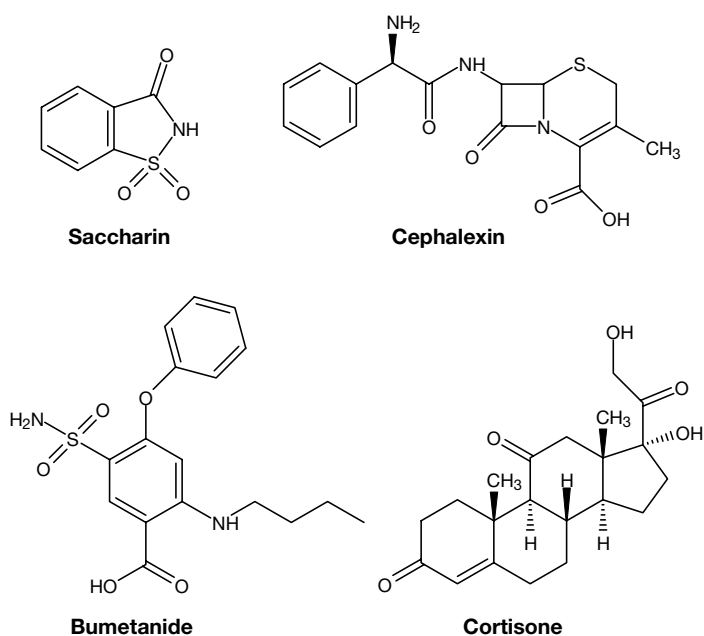

Figure 1. Chemical structures of analytes investigated in the study

## Instrumentation

Thermo Scientific™ Vanquish™ Flex Duo UHPLC system for Inverse Gradient consisting of:

- System Base Vanquish Flex (VF-S01-A)
- Dual Pump F (VF-P32-A)
- Split Sampler HT (VH-A10-A)
- Column Compartment H (VH-C10-A02)
- Charged Aerosol Detector H (VH-D20-A)
- Variable Wavelength Detector (VF-D40-A) with standard flow cell 7 mm, 2.5 µL (P/N 6077.0360)
- Workflow Kit, Vanquish Duo for Inverse Gradient (P/N 6036.2010)

During method development, optimization of CAD parameters was performed according to Technical Note 71290: Guidelines for Method Transfer and Optimization – From Earlier Model Corona Detectors to Corona Veo Detectors.<sup>3</sup> The optimized parameters for power function value (PFV), evaporation temperature, and digital filter setting were determined to be 1.1, 35 °C, and 1.0 s, respectively. In this technical note, the differences are demonstrated by an example method that clearly emphasizes the related effects, rather than by a typical application. A steep gradient that started at 10% B and rose to 40% in 0.1 min was used for this (Table 1).

## Chromatography data system

Instrument control, data acquisition, and processing were performed with the Thermo Scientific™ Chromeleon™ 7.3 Chromatography Data System (CDS) software.

**Note:** The option of the inverse gradient wizard for “minimize flow” can be used from CM version 7.3 for automated method creation. Earlier versions of Chromeleon need manual method adjustments.

**Table 1. Chromatographic conditions for the analytical flow path**

Parameter	Value	
Column	Thermo Scientific™ Hypersil GOLD™ aQ, 100 x 2.1 mm, 1.9 µm (P/N 25302-102130)	
Mobile phase	A: 10 mM ammonium acetate B: acetonitrile	
Flow rate	0.3 mL/min	
Analytical gradient	Time [min]	%B
	0.0	10
	2.0	10
	2.1	40
	8.0	40
	8.1	10
Equilibration time	10 min	
Column temperature	30 °C (with active pre-heater at 30 °C), forced air mode with fan speed 5	
Injection volume	5.0 µL	
UV detector settings	Wavelength 254 nm, data collection rate 10 Hz, response time 0.5 s	
CAD settings	Evaporation temperature 35 °C, PFV 1.1, data collection rate 10 Hz, filter 1.0 s	

## Inverse gradient

In contrast to the constant mobile phase composition in an isocratic chromatographic run, the mobile phase composition changes with gradient elution. The increase or decrease of organic solvent in the mobile phase leads to a different detector response in CAD, which can be explained by differences in the viscosity and surface tension of the solvents. The lower the viscosity and surface tension of the mobile phase, the more efficient the droplet generation and consequently the greater the analyte mass transport, which leads to an increase in detector response.<sup>4</sup> However, to minimize signal changes and to obtain uniform response for gradient elution, an inverse gradient approach should be used when no individual standards are available. For this, a second flow is introduced, using a T-piece after the analytical column but before the entrance to the CAD (Figure 2). To achieve accurate gradient compensation, implementation of an inverse gradient offset volume is required. This value incorporates any differences in volume between the analytical and inverse flow path (instrument, column, and capillary volumes) and ensures that inverse and analytical gradients reach the detector at the same time. If an equal column is used in the inverse flow path, the volume difference is given only by the extra dwell volume of the autosampler. In order to reduce analysis costs and complexity, the second column in the inverse flow path can be replaced by a viper capillary (Figure 2, #7) included in the Workflow Kit for Vanquish Duo for Inverse Gradient. In addition, a Thermo Scientific™ nanoViper™

capillary may be required to exceed the lower pressure limit of the pump with >20 bar (Figure 2, #7a). In this case capillary #7 and #7a are connected via a zero-dead-volume Viper union (P/N 6040.2304). Optionally, a post-column cooler (P/N 6732.0510) can replace capillary #3, as needed (refer to Installation Guide – Thermo Scientific™ Vanquish™ Duo for Inverse Gradient<sup>5</sup> for more details).

The Chromeleon software automatically calculates an inverse gradient offset based on the instrument configuration and column parameters.<sup>5</sup> The use of the pre-defined capillary dimensions, as shown in Figure 2, is a prerequisite. The contribution of the column volume to the total inverse gradient offset can be calculated by the software after defining the fluidic instrument configuration.<sup>2</sup> Please note that the volume of the additional nanoViper capillary is not considered within the calculation, as it is not included in the Workflow Kit. However, with 1.9 µL capillary volume the contribution to the total volume is negligible.

Chromeleon CDS offers three inverse gradient options to provide flexibility for different application approaches. Available options are:

- Keep solvent composition
- Maximize %A, %B, %C
- Minimize flow

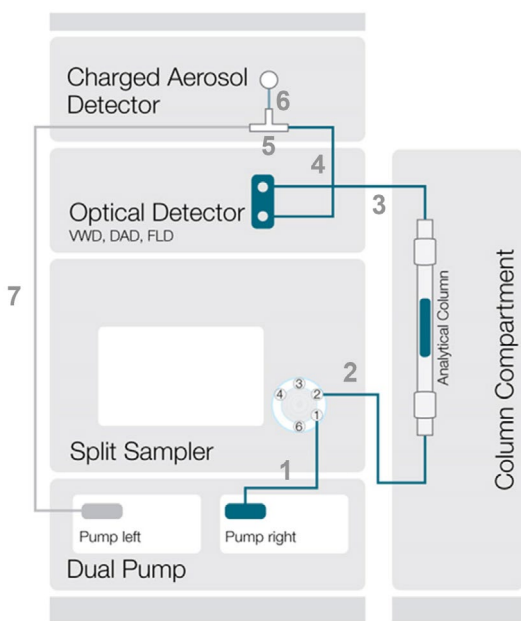

#	Capillary ID × L (mm)	P/N
1	0.1 × 350	6042.2340
2	0.1 × 380 (Active pre-heater)	6732.0110
3	0.1 × 350* (for VF-D40-A)	6083.7950
4	0.1 × 350	6042.2340
5	Tee Piece (0.5 mm)	6263.0035
6	0.1 × 65	6042.2306
7	0.1 × 950	6042.2395
7a**	0.050 × 950	6041.5125

\*The capillary dimension depends on the optical detector installed

\*\*If the pump pressure is <20 bar, capillary #7 and #7a are connected via a Viper union

Figure 2. Fluidic scheme of the Vanquish Duo UHPLC for inverse gradient with an additional optical detector as used in the study

### Option 1: Keep solvent composition

The “Keep solvent composition” option is where the gradient profile is strictly inverted. The example in Figure 3 shows that the initial organic condition of the analytical gradient method is set to 10% B and raised to 40% B during the gradient profile. The composition and profile of the inverse gradient is the exact opposite of the analytical gradient, starting with 40% B and decreasing

to 10% B. The resulting composition that finally reaches the detector is calculated to be constantly 25% B with consideration of the inverse gradient offset (Figure 3-B). The flow rate of both, the analytical and inverse gradient flow paths, remain the same with 0.3 mL/min for this option, which results in a total flow rate of 0.6 mL/min to the CAD.

**A**

Analytical Gradient		Inverse Gradient			
No	Time	Flow [ml/min]	%B	%C	Curve
1	0.000	Equilibration			
2	0.000	0.300	10.0	0.0	5
3	<i>New Row</i>				
4	0.000	Run			
5	2.000	0.300	10.0	0.0	5
6	2.100	0.300	40.0	0.0	5
7	8.000	0.300	40.0	0.0	5
8	8.100	0.300	10.0	0.0	5
9	<i>New Row</i>				
10	18.000	Stop Run			

**B**

Analytical Gradient		Inverse Gradient			
No	Time	Flow [ml/min]	%B	%C	Curve
1	0.000	Equilibration			
2	0.000	0.300	40.0	0.0	5
3	<i>New Row</i>				
4	0.000	Run			
5	1.297	0.300	40.0	0.0	5
6	3.297	0.300	40.0	0.0	5
7	3.397	0.300	10.0	0.0	5
8	9.297	0.300	10.0	0.0	5
9	9.397	0.300	40.0	0.0	5
10	<i>New Row</i>				
11	18.000	Stop Run			

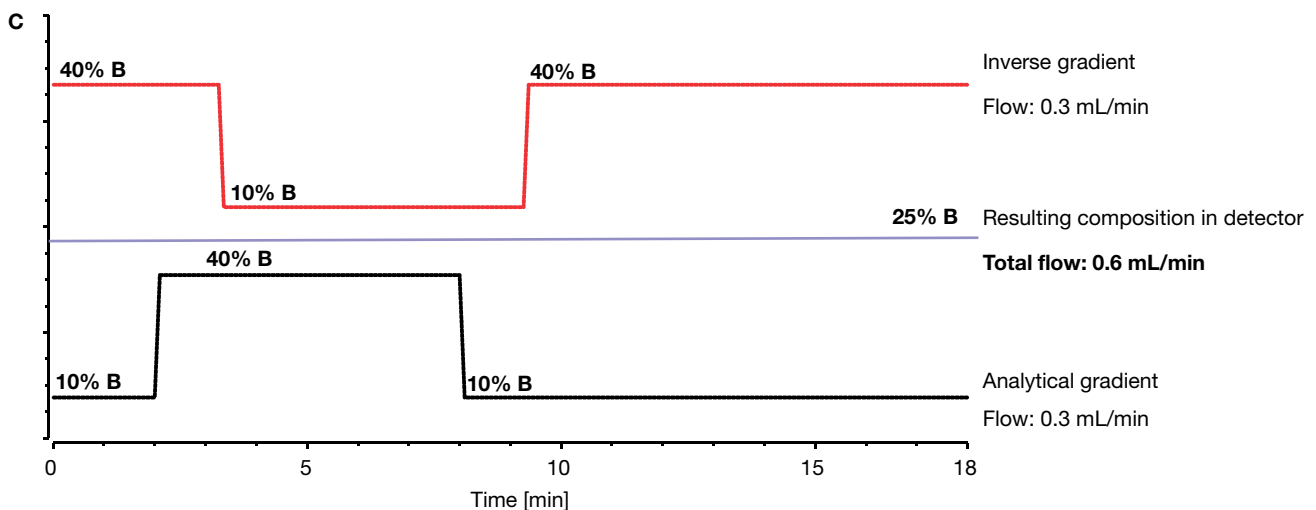
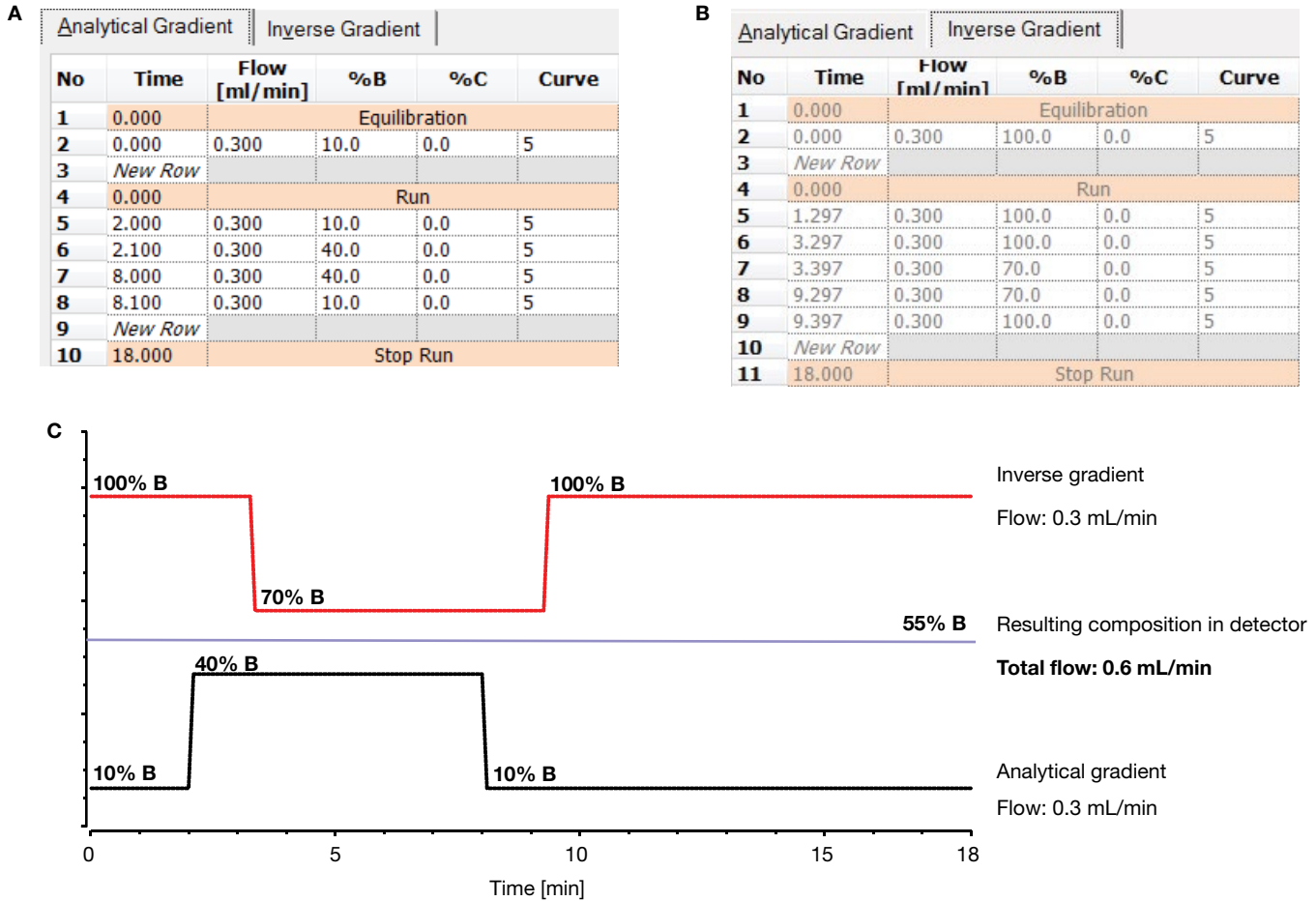

**Figure 3.** Gradient tables (A) analytical gradient, (B) inverse gradient, and profiles (C) of the option “Keep solvent composition”. The resulting composition at the detector is 25% B with a total flow of 0.6 mL/min. To achieve accurate compensation, a delay time for the inverse gradient is implemented.

### Option 2: Maximize %A, %B, %C

This option should be used to maximize the organic portion of the total flow to the detector in order to achieve higher sensitivity. If the organic solvent is installed in A, then choose Maximize %A, if in B use Maximize %B and if in C use Maximize %C. This option can be used as long as the organic content can still be maximized. Therefore, this option cannot be used with analytical gradients covering the entire range from 0 to 100% B. Figure 4 shows the

same analytical gradient as used for option 1 but a different resulting inverse gradient composition. The mobile phase composition reaching the detector is constantly 55% B, maximizing organic content with 100% B in the beginning of the inverse gradient ramp. Both flow paths run at 0.3 mL/min for this option, which yields a total flow rate of 0.6 mL/min entering the CAD.



**Figure 4. Gradient tables (A) analytical gradient, (B) inverse gradient, and profiles (C) of the option “Maximize %B”.** The resulting composition at the detector is 55% B with a total flow of 0.6 mL/min. To achieve accurate compensation, a delay time for the inverse gradient is implemented.

### Option 3: Minimize flow

Flow rates >2.0 mL/min may cause flooding and damage to the CAD and must be strictly avoided. If the combined flow rates (analytical and inverse gradient) exceed this detector limit of 2.0 mL/min, the minimize flow option can be used instead of splitting the flow, which would require a more complex fluidic setup. In this option, the flow rate of the inverse gradient flow path is minimized and is always lower than in the analytical flow path. When calculating the flow rate, the dead volume of the analytical flow path, which

consists of the gradient delay volume and the column void volume, must be taken into account. The organic composition is adjusted to the minimized flow and gradient times. Here, the inverse gradient starts with 58.4% B and decreases to 0% B at the top of the analytical gradient ramp (Figure 5). The resulting mobile phase composition is calculated to be constantly 26.4% B, with a flow rate of 0.3 mL/min for the analytical and 0.154 mL/min for the inverse flow path.

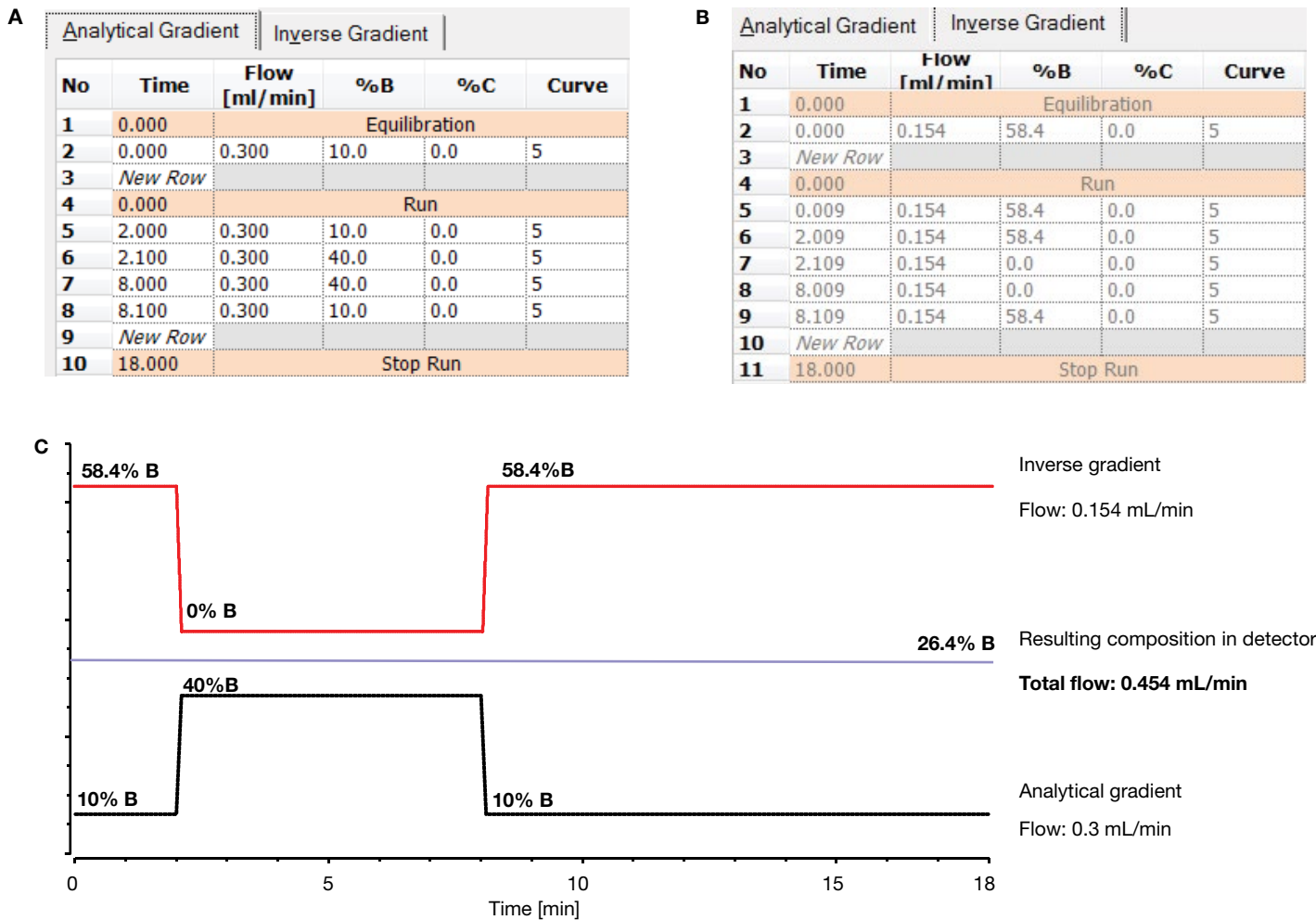

Figure 5. Gradient tables (A) analytical gradient, (B) inverse gradient, and profiles (C) of the option “Minimize flow”. The resulting composition at the detector is 26.4% B with a total flow of 0.454 mL/min.

## Results and discussion

How do these three options for an inverse gradient workflow differ?

### Use Case 1 – Uniform response and universal calibration

Figure 6 shows two chromatograms: (A) obtained with UV detection and (B) with CAD but without applying an inverse gradient. Both detectors can detect the analytes investigated in the study (Figure 1). However, neither the UV detector nor the CAD show uniform response.

To achieve response uniformity, the inverse gradient workflow must be applied. Figure 7 shows two chromatograms that highlight the differences in response seen when applying the inverse gradient, in this case using option 1, “Keep solvent composition” (refer to Figure 3 for more details). As shown in Figure 7A, for the analysis

without the inverse gradient, the CAD response for analytes that elute during the highly aqueous portion in the beginning of the gradient in RP-HPLC is typically lower relative to the analytes eluting with higher organic content. After applying the inverse gradient flow, shown in Figure 7B, the detector response is more uniform because the organic/aqueous ratio does not change during the run. In Figure 7B, the red line showing the inverse gradient drops from 40% to 10% B at around three minutes, whereas the black line showing the analytical gradient already increases from 10% to 40% B at around two minutes. This delay time between the analytical gradient and the inverse gradient achieves accurate compensation by taking instrument volumes, capillary volumes, and the column volume into account. Because the inverse gradient has a lower volume flow path, it is delayed relative to the analytical gradient.

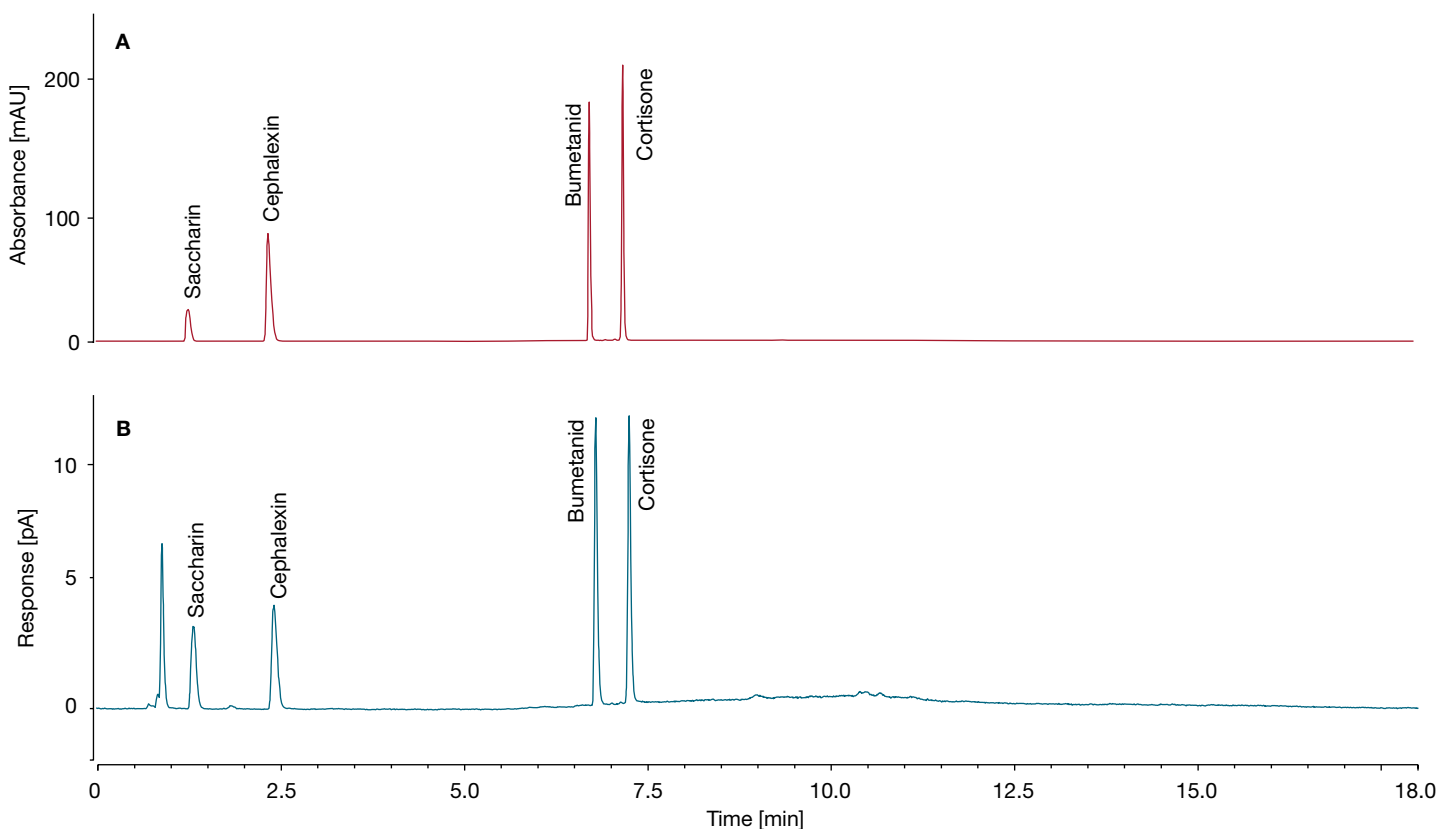
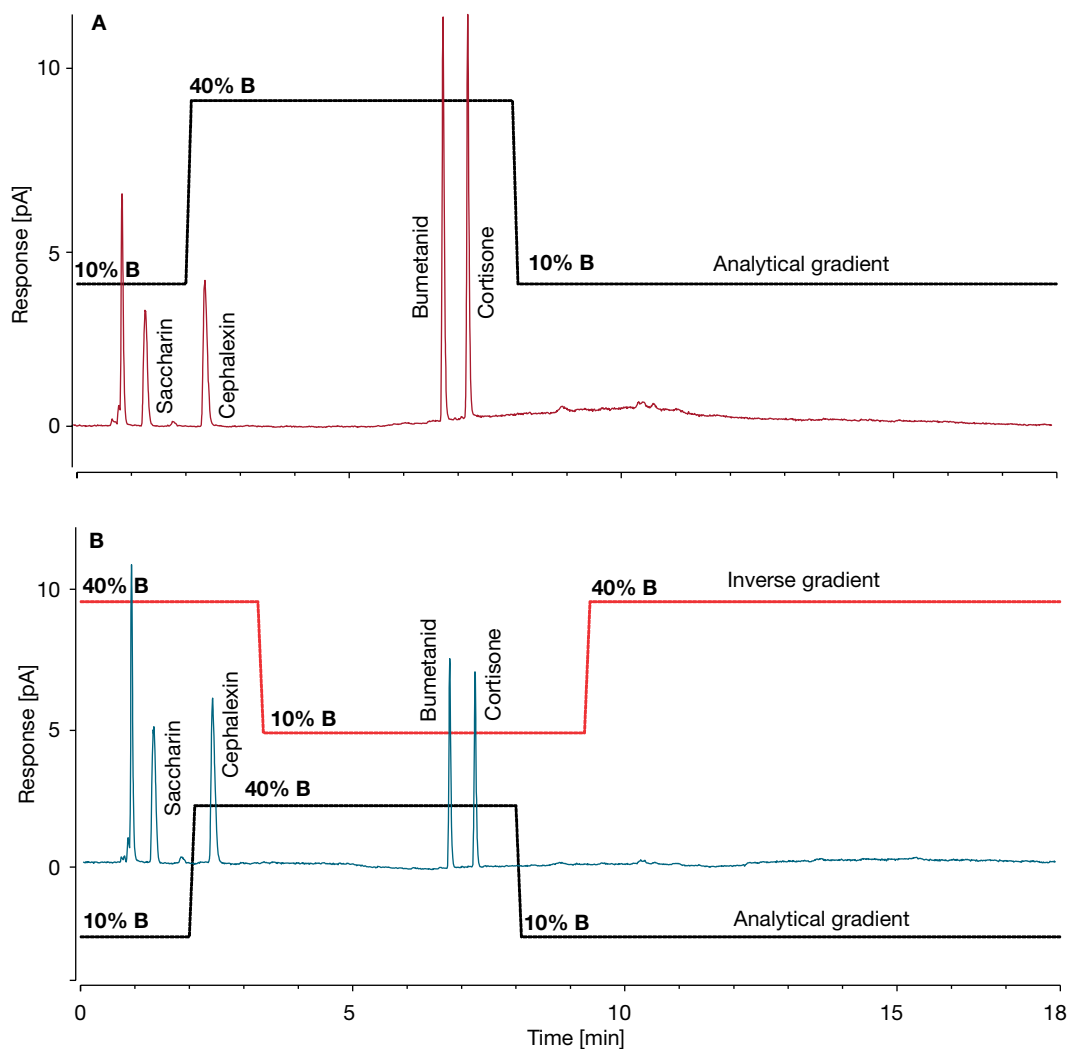

Figure 6. Chromatograms of four analytes (A) UV trace and (B) CAD response without using inverse gradient (CAD regular). 5.0  $\mu$ L injection of standard solution with 20  $\mu$ g/mL each





**Figure 7. CAD chromatograms of (A) analytical gradient only and (B) inverse gradient (keep solvent composition).** 5.0  $\mu$ L injection of standard solution with 20  $\mu$ g/mL

With the inverse gradient method, the response of early-eluting analytes is somewhat higher and that of late-eluting analytes is somewhat lower, as illustrated in Figure 8. Possible factors that could result in over- or under-compensation are the purity of the standard, water absorption or loss, weighing of hygroscopic/static charged analytes (such as cephalalexin), and salt formation. Technical Note 72806 describes how these factors contribute to the observed differences and can be further studied using flow injection analysis with certified standards.<sup>2</sup> Nevertheless, the relative standard deviation of the analyte response (RSD response) decreases from 28% obtained in the CAD regular mode to 18% obtained for the inverse gradient method. Another factor can be a deviation in the calculation of the column volume, using the column geometry and a universal factor for porosity. If these values are not ideal for the column used, the GDV settings in the wizard would need to be adjusted to achieve a more precise gradient compensation.

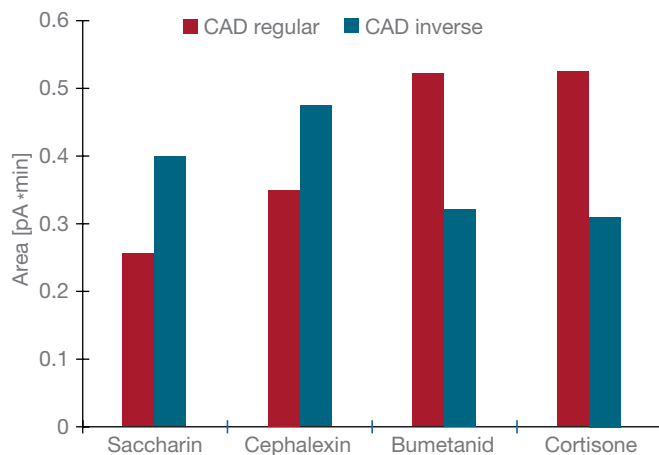

**Figure 8. Analyte response comparison of analytical gradient only (CAD regular) and CAD inverse (keep solvent composition).** Averaged values (n=5); CAD response uniformity, measured as RSD between analytes, was improved from 28% without inverse gradient to 18% with inverse gradient.

Due to its more uniform response, CAD is an ideal technique for quantitation, when individual reference standards are not available or their use is not practical. With CAD, a single calibrant can be applied for all analytes contained in the sample (universal calibration), while for UV/VIS detection each compound requires a corresponding calibration curve. A published application note demonstrates the utilization of a universal calibration on the example of the drug paclitaxel and the quantitation of its related impurities detected in the sample.<sup>6</sup>

### Use Case 2 – Focus on highest sensitivity for the application when using inverse gradient

Sometimes the application requires the highest sensitivity for analysis. For this purpose, option 2 (maximize %A, %B, %C) can be used. Because a higher constant organic amount enters the detector with 55% B instead of 25% B for option 1 (keep solvent composition) (Figure 3 and Figure 4), a higher peak area can be achieved, as well as a better signal-to-noise (S/N) ratio, due to a more efficient nebulization process. Furthermore, a lower flow rate also leads to a more efficient nebulization and drying process, which can be achieved with option 3 (minimize flow). An overview of the three options in terms of peak area and S/N ratio is given in Figure 9. The S/N ratio was determined using a fixed one-minute region in the chromatogram in which no peaks were present (at time 4-5 min).

In general, the highest analyte response and S/N ratio is obtained when using the maximize %B option. The results demonstrate that increasing the amount of organic solvent entering the detector provides a greater increase in sensitivity than minimizing the flow. However, the benefit of increased sensitivity with option 2 needs to be evaluated

with respect to the higher costs and environmental impact of greater organic solvent consumption. These aspects are discussed in more detail in the next section. It must also be mentioned that detection limits do not automatically increase with a higher organic content, since a higher mass transport is also obtained for impurities, which can lead to increased baseline noise. Therefore, the observed detection limits also depends on the purity of the solvents and additives, as well as the amount of column bleed or system cleanliness.

Another approach for using options 2 and 3 is sample analysis with a multi-detector setup, in which a MS is combined with the CAD.<sup>7</sup> Since nebulization also takes place in the MS ion source, the analyte response benefits from an increased organic composition or a reduction in flow.

### Use Case 3 – Cost and environmentally conscious aspects when using inverse gradient

An overview of solvent consumption and analysis costs comparing the three options for the inverse gradient workflow is presented in Figure 10.

The organic solvent consumption for maximize %B option is almost double that of the other two options, which results in significantly higher waste and analysis costs. In particular, acetonitrile has become very expensive since the crisis in 2008. In addition to the financial aspect, environmental aspects should also be carefully considered. The philosophy of green chemistry aims to prevent, or at least minimize, environmental pollution to reduce the negative impact on the environment and protect human health.<sup>8</sup> The attention to green chemistry approaches has increased in the recent years.<sup>9</sup> Since the common solvents,

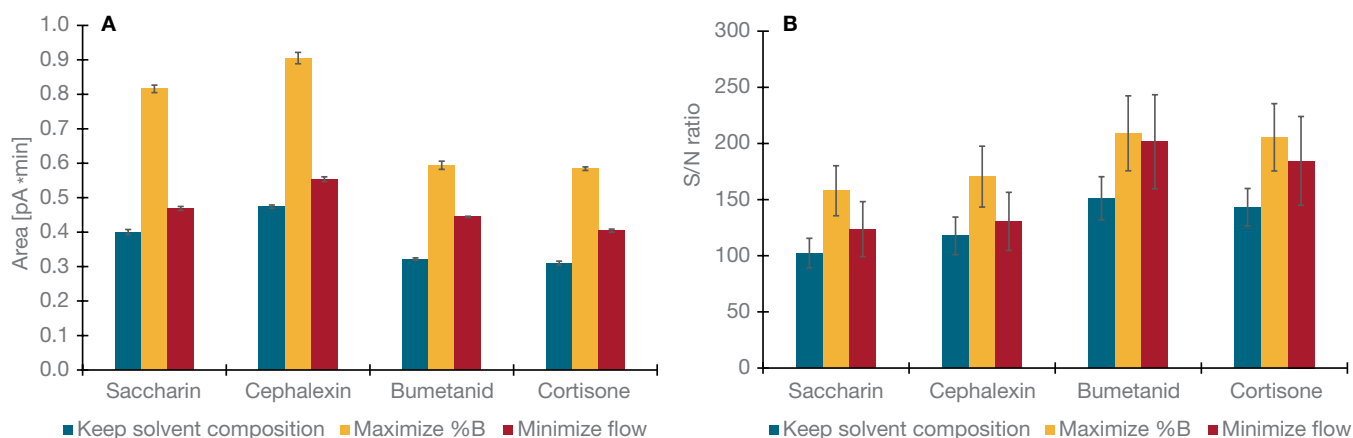

**Figure 9. Comparison on analyte response (A) and S/N ratio (B) with error bars (standard deviation) of the three inverse gradient options.** 5.0  $\mu$ L injection of standard solution with 20  $\mu$ g/mL; averaged values (n=5); highest analyte response and S/N ratio are obtained with maximize %B option.

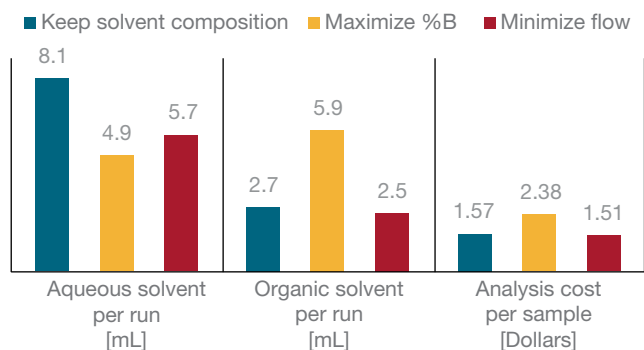

**Figure 10. Comparison between three inverse gradient options with respect to organic solvent consumption and cost per sample.** The cost per sample takes into account the actual price of acetonitrile and the column (assuming 1000 injections per column).

such as acetonitrile and methanol, are mainly used for (U)HPLC applications, a complete replacement of these toxic solvents is difficult to achieve. Therefore, minimizing solvent consumption while maximizing analysis efficiency is the desired goal.

To conclude, with the maximize %B option the highest sensitivity can be achieved, but this is associated with an increased organic solvent consumption and analysis cost per sample. Therefore, it is recommended to choose this option only if the application truly requires high sensitivity.

## Conclusion

Advantages and disadvantages of the individual options are as follows:

- **Keep solvent composition:** This is the preferred option if the sensitivity of the application is sufficient. The profile of the inverse gradient is the exact opposite of the analytical gradient. Under these conditions, CAD response among non-volatile analytes is more uniform, which allows more accurate quantitation with a single calibrant.
- **Maximize %B:** This option should be used if the application requires a higher sensitivity. The organic

portion of the inverse gradient method is maximized while the profile of the inverse gradient is kept constant. This option results in the highest analyte response and S/N ratio but the increased sensitivity comes with the disadvantage of higher organic solvent consumption and thus higher analysis and waste costs, compared to that of the “Keep solvent composition” or “Minimize flow” options.

- **Minimize flow:** This option can be used to prevent the flow rates of the combined flow path from being higher than 2.0 mL/min, which would result in flooding and damage to the CAD. The flow and organic portion are set based on the different volumes of both flow paths so that the gradient starts at the same time. With this option the analyte response and S/N ratio are comparable to those for “Keep solvent composition”, while the analysis costs are the same.

## References:

1. Charged Aerosol Detection for Liquid Chromatography and Related Separation Techniques. Gamache, P. H. (ed.), Chapters 2.2, page 75, Wiley 2017.
2. Thermo Fisher Scientific Technical Note 72806, Charged Aerosol detection – factors affecting uniform analyte response. <https://assets.thermofisher.com/TFS-Assets/CMD/Technical-Notes/tn-72806-uhplc-charged-aerosol-detection-tn72806-en.pdf>
3. Thermo Fisher Scientific Technical Note 71290, Guidelines for Method Transfer and Optimization — From Earlier Model Corona Detectors to Corona Veo Detectors. <https://assets.thermofisher.com/TFS-Assets/CMD/Technical-Notes/tn-71290-cad-method-transfer-tn71290-en.pdf>
4. Charged Aerosol Detection for Liquid Chromatography and Related Separation Techniques. Gamache, P. H. (ed.), Chapter 4.5, page 204, Wiley 2017.
5. Installation Guide - Thermo Scientific™ Vanquish™ Duo for Inverse Gradient.
6. Thermo Fisher Scientific Application Note 72594, Quantification of paclitaxel, its degradants, and related substances using UHPLC with charged aerosol detection. <https://assets.thermofisher.com/TFS-Assets/CMD/Application-Notes/an-72594-ic-cad-paclitaxel-an72594-en.pdf>
7. Thermo Fisher Scientific Application Note 72869, A multi-detector platform comprising UV/Vis, charged aerosol, and single quadrupole mass spectrometric detection for comprehensive sample analysis. <https://assets.thermofisher.com/TFS-Assets/CMD/Application-Notes/an-72869-ic-ms-multi-detector-analysis-an72869-en.pdf>
8. Charged Aerosol Detection for Liquid Chromatography and Related Separation Techniques. Gamache, P. H. (ed.), Chapter 4.7, page 207-209, Wiley 2017.
9. S. Armenta, M. de la Guardia, Green Analytical Chemistry, vol. 57, Comprehensive Analytical Chemistry Series, Elsevier, Amsterdam, 2010.

Find out more at [thermofisher.com/CAD](https://thermofisher.com/CAD)