

Recent Advances in Sample Preparation by a New Accelerated Solvent Extraction Technique

Chris Shevlin – Scientific Affairs Manager
Thermo Fisher Scientific
NEMC 2022 – Crystal City, VA
August 2, 2022

 The world leader in serving science



Agenda

1. Sample Prep Today
2. Gas Assisted Extraction
3. Automated Parallel Extraction
4. Fully Automated Concentration
5. Conceptual Device Data
6. Questions

1. Sample Prep Today

 The world leader in serving science

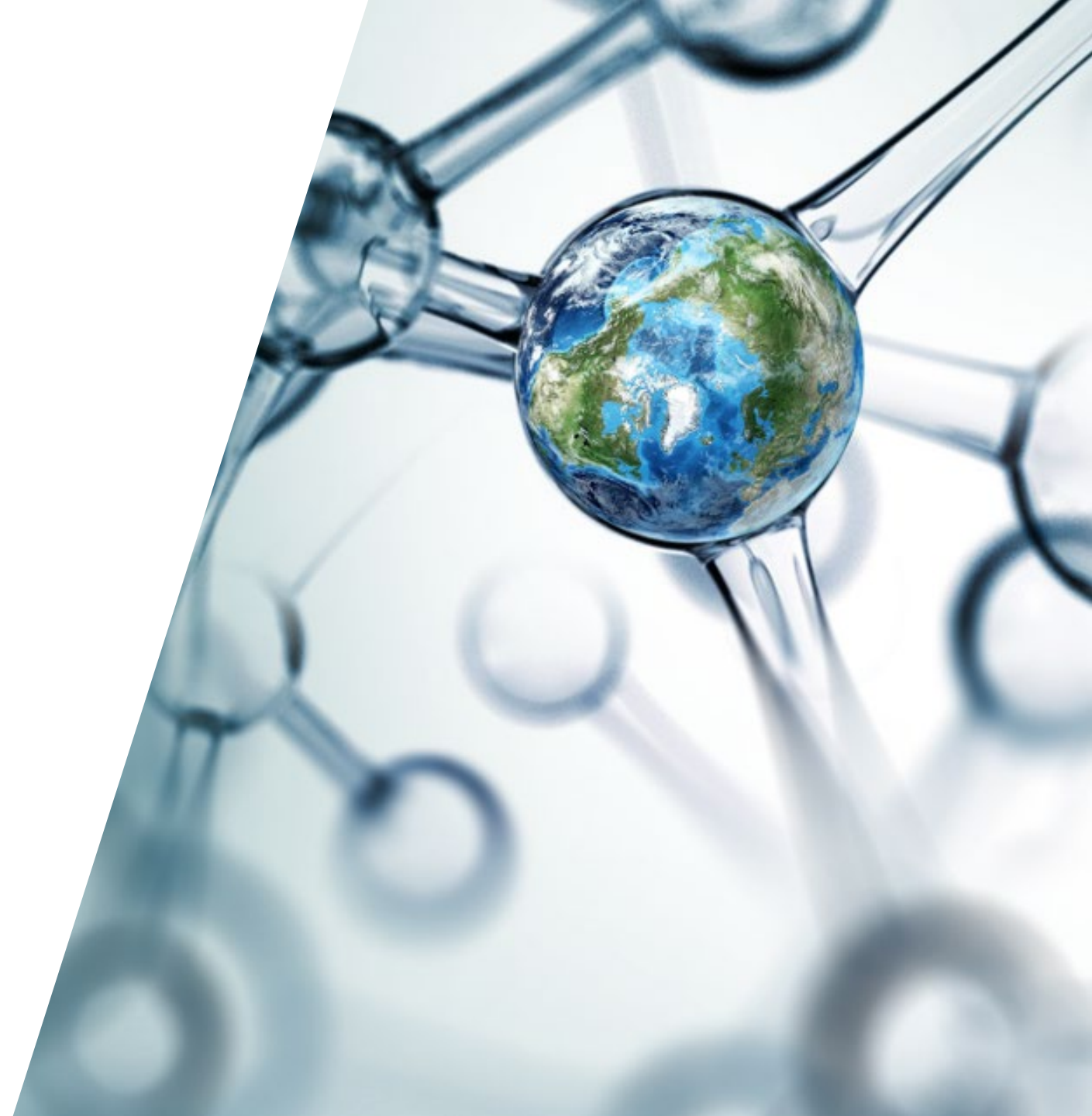

Current Instrumentation

- Most are single, sequential extraction
- Extraction is based on hold cycles
 - Cell is pressurized with solvent and held for a user defined time
 - Limited control over extraction parameters
 - Little or no flow rate control
 - Pressure and temp are the only adjustable parameters
- Samples must be manually transferred to evaporation instrument or device
- Limited sample tracking capabilities

Current Instrumentation

- Samples must be manually transferred from the extraction instrument or device
- Process must be monitored when targeting a specific volume
- Not all sample evaporate at the same rate
 - No mechanism for stopping samples which have finished
 - The device needs to be constantly stopped and restarted

Manual Sample Prep

- Time consuming
 - Manual methods require a lot of time and constant attention
 - Setup and clean up takes longer using manual methods
 - Sample must be manually transferred between preparation devices
- Meeting method performance requirements (recoveries and reproducibility)
 - Manual prep introduces variables which can affect quality of the prep
- Controlling lab costs
 - More solvents used compared to automated methods
 - Increased risk of errors and resampling when manual processing samples
- Sample throughput – Manual prep takes a long time
- Sample data tracking and integrity
 - Documentation is mostly manual



2. Gas Assisted Extraction

 The world leader in serving science

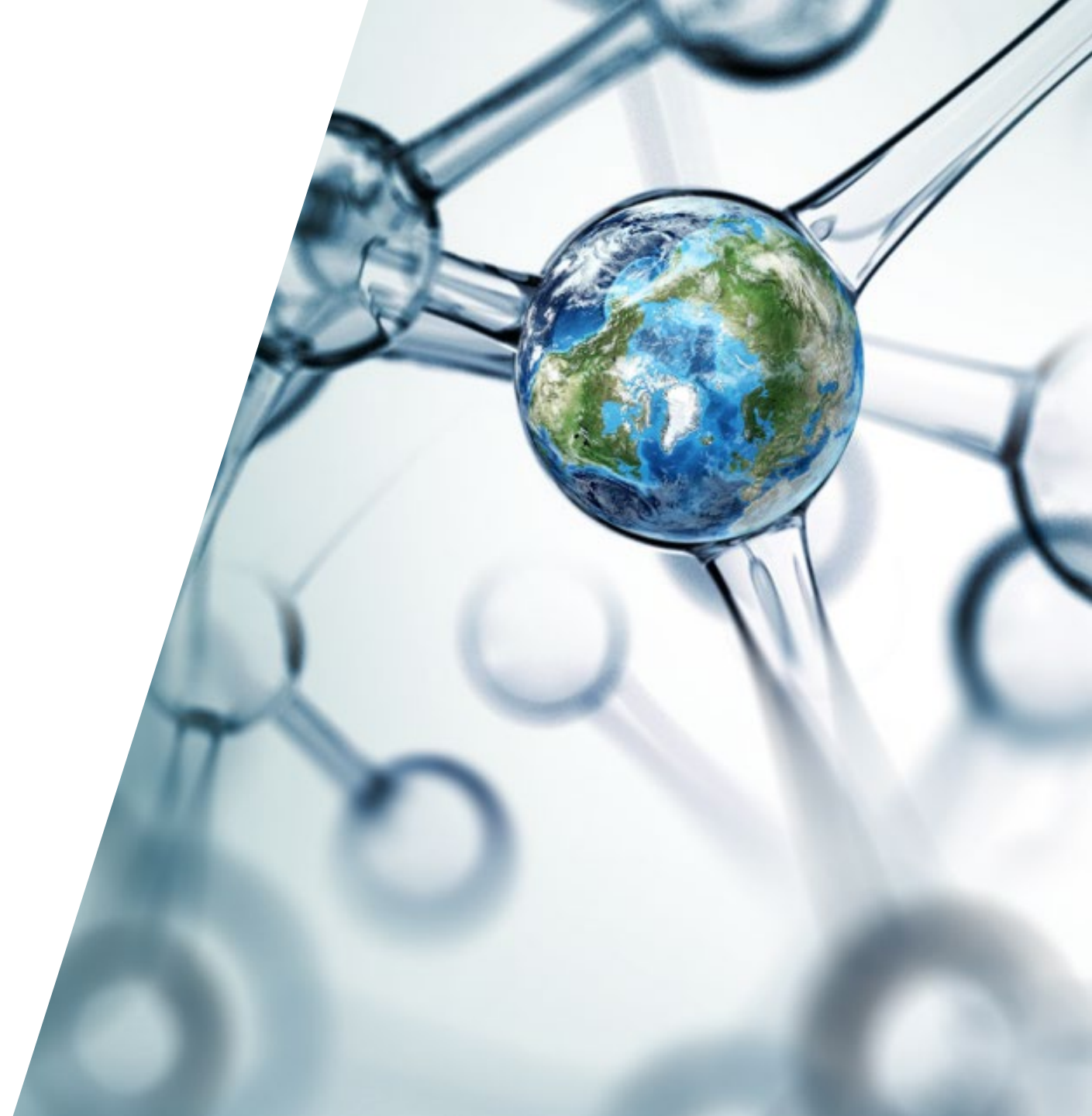

Traditional extraction mechanism

Step 1: Loading the Cell

Step 2: Filling the Cell

Steps 3 and 4: Heating and Static

Step 5: Rinsing the Cell

Step 6: Purging

Step 7: Relief

Step 8: Unloading the Cell

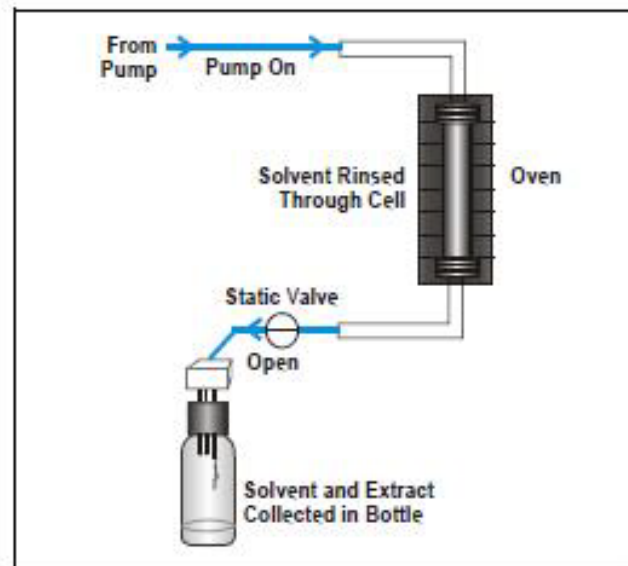
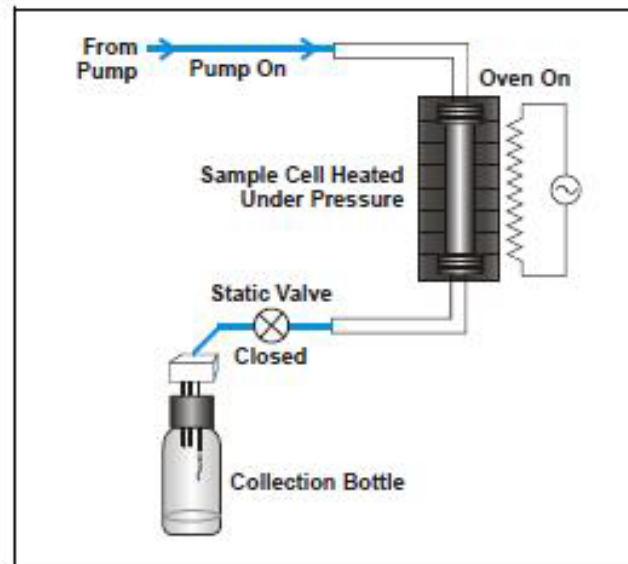

SYSTEM STATUS

STATUS: HEATING CELL
 MODE: STANDARD
 MET #: 1 SEQ #: 1 LOCAL
 TIME REMAINING: 8:00
 TIME STEP: 0:04
 TEMP: SET 40 C ACTUAL: 40 C
 PRESSURE: 1500 PSI
 CELL #: 1 SIZE: 100
 BTL/VIAL#: 1 VOLUME: 55.0 mL

Help prompt

What can I do with more control over the extraction process?

Gas assisted extraction

- Solvent is added for a short period of time
- Gas follows for the second period of time
- Pressure and flow rate can be precisely controlled
- Segmented alternating flow of solvent and gas follows at a user determined flow rate
- During the entire extraction, the cell is heated and held at high pressure

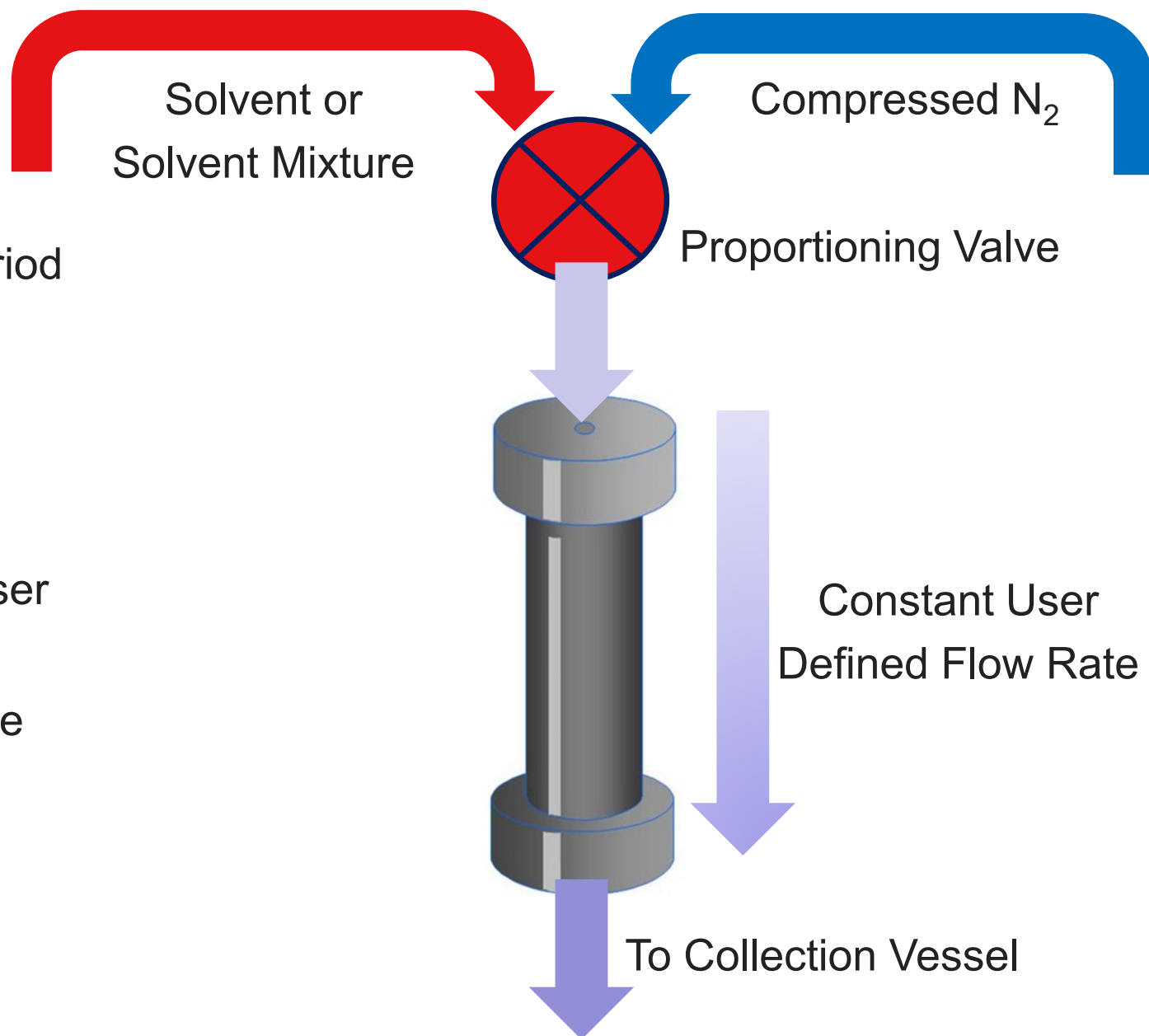

Advantages of gas assisted extraction

- Further reduces the amount of solvent required compared to accelerated or pressurized fluid extraction – Additional cost savings for the lab
- Precise flow rate and cell pressure control – Improves method development capabilities
- Provides an efficient extraction method – Helps meet method performance requirements

Solvent Flow Rate (mL/min)	N2 Gas Pressure (PSI)	Lipid Recovery %	Solvent Collected (mL)
0.50	0	88.2	13
0.50	30	86.0	13
0.50	40	92.9	13
0.50	45	93.8	12
0.50	50	94.1	11
0.50	55	94.8	11
0.50	60	95.8	10
0.50	70	96.5	9
0.50	90	96.5	7

3. Automated Parallel Extraction

 The world leader in serving science

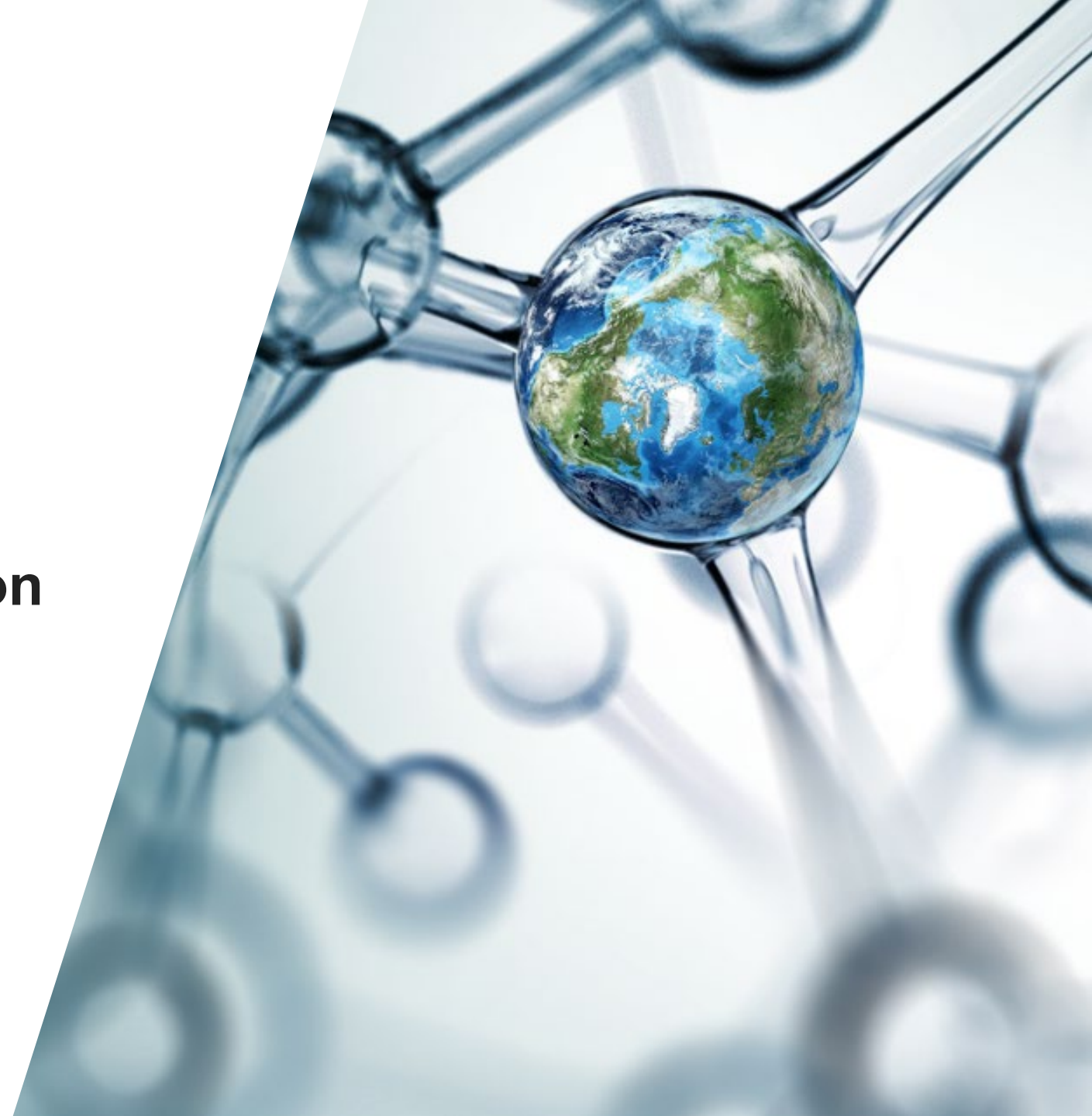

Parallel extractions

- Many labs identify sample prep as a bottleneck to sample throughput
- Most automated instruments extract samples one by one

Benefits to 4 channel extraction:

- Faster sample prep
- Higher throughput - More samples processed during the same time as it takes to do one
- Many sample cells can be setup and placed on the instrument for walk-away operation
- Using the same cells which are available today

Parallel extraction setup

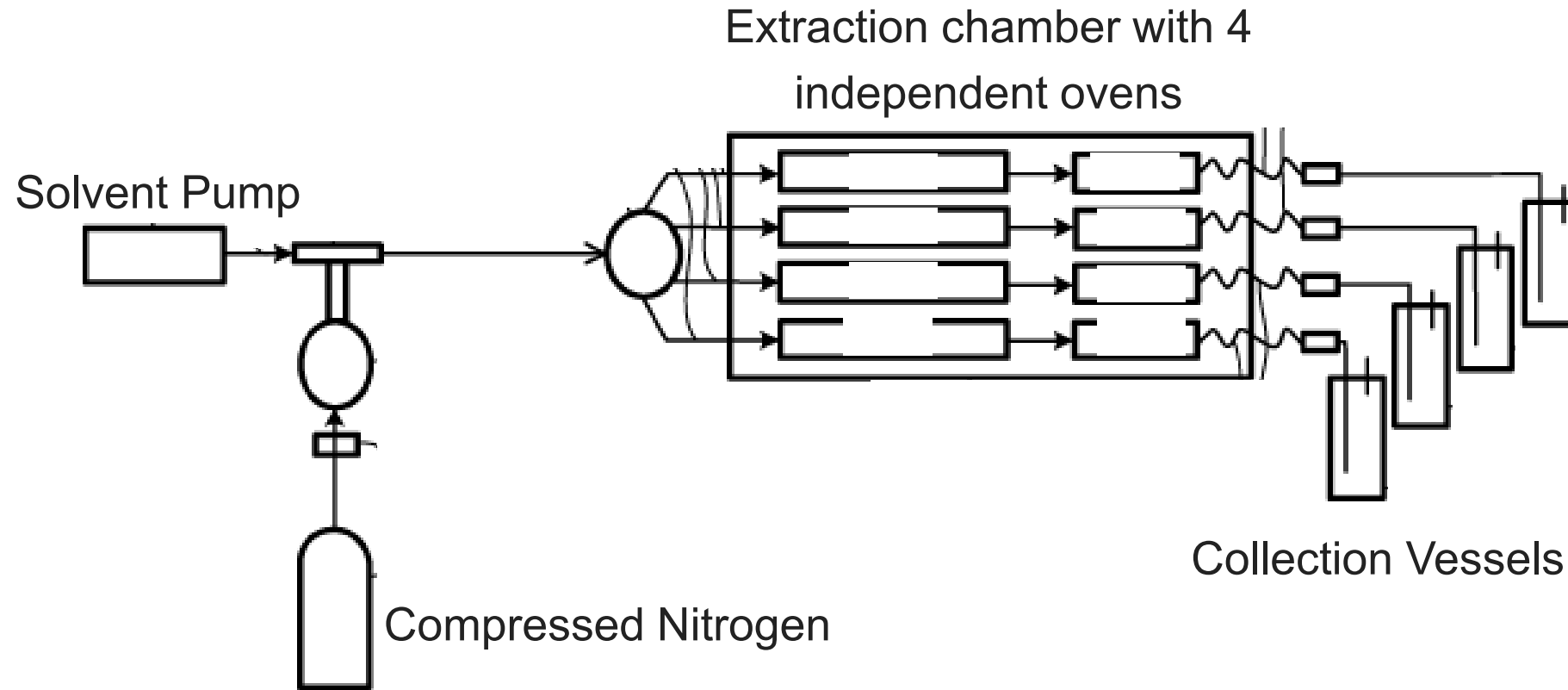

4. Fully Automated Concentration

 The world leader in serving science

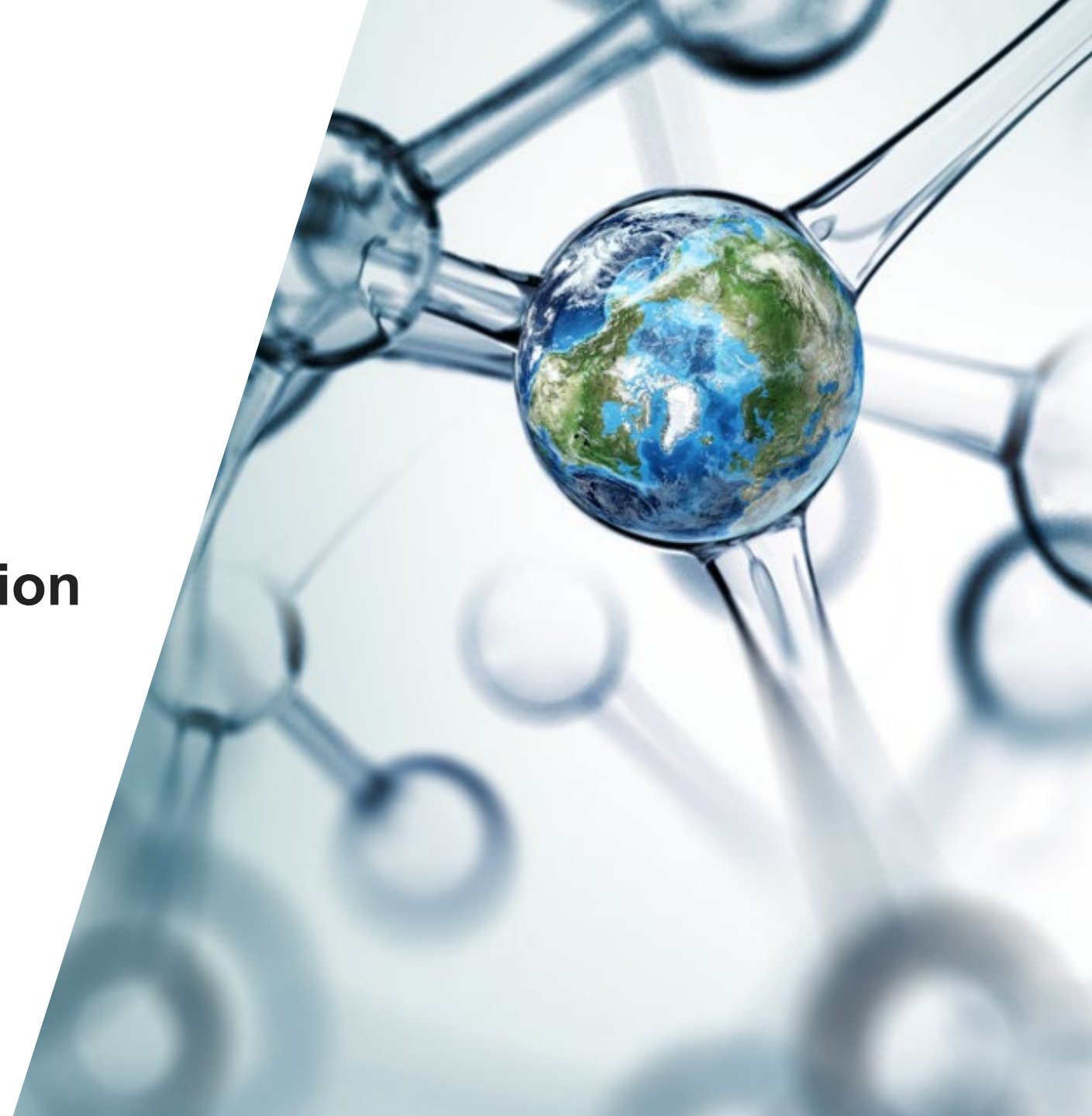

Combining extraction and evaporation

Why combine two operations?

- Allows for true walk-away sample prep
- Less user intervention required for the entire process
- Analyte can dedicate time to more important tasks
- Alleviates worry of errors, spills or the need for purchase and maintain multiple devices
- Fewer items to setup and clean

Conceptual design:

- Vacuum and nitrogen would connect directly to the collection vessels
- Combined mode would help facilitate evaporation
- Incorporate the GC or LC vial into the collection vessel

Combined extraction concentration concept



Automated end-point detection

Today evaporation must be monitored, especially when concentrating to a desired volume such as 1 mL

- Does not allow for true walk away sample prep

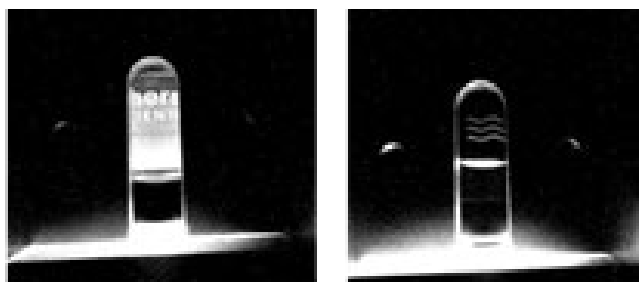
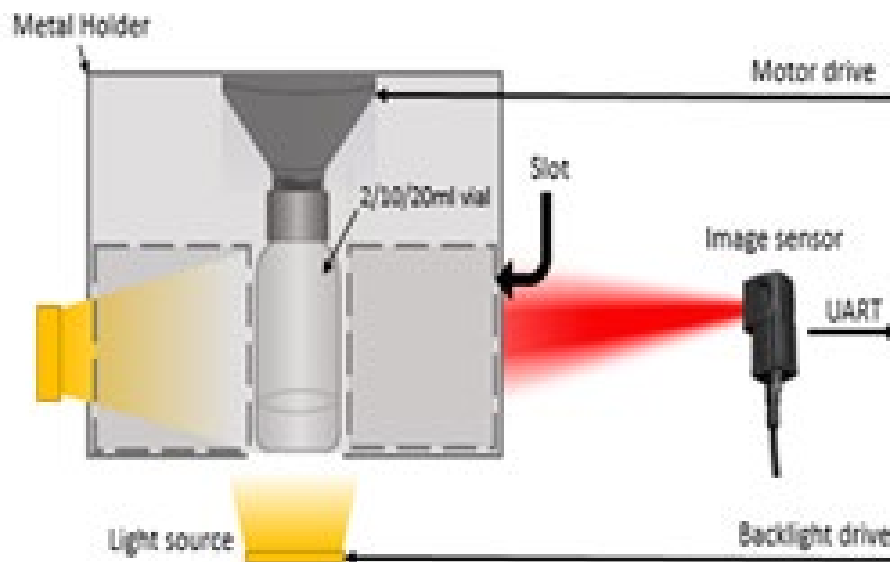

Automated end-point detection using machine learning solves this issue

- Using an image sensor and proper backlighting allows the instrument to get a real picture of the evaporation level
- Machine learning is employed to teach the instrument to stop at the process at the desired level

Highlights

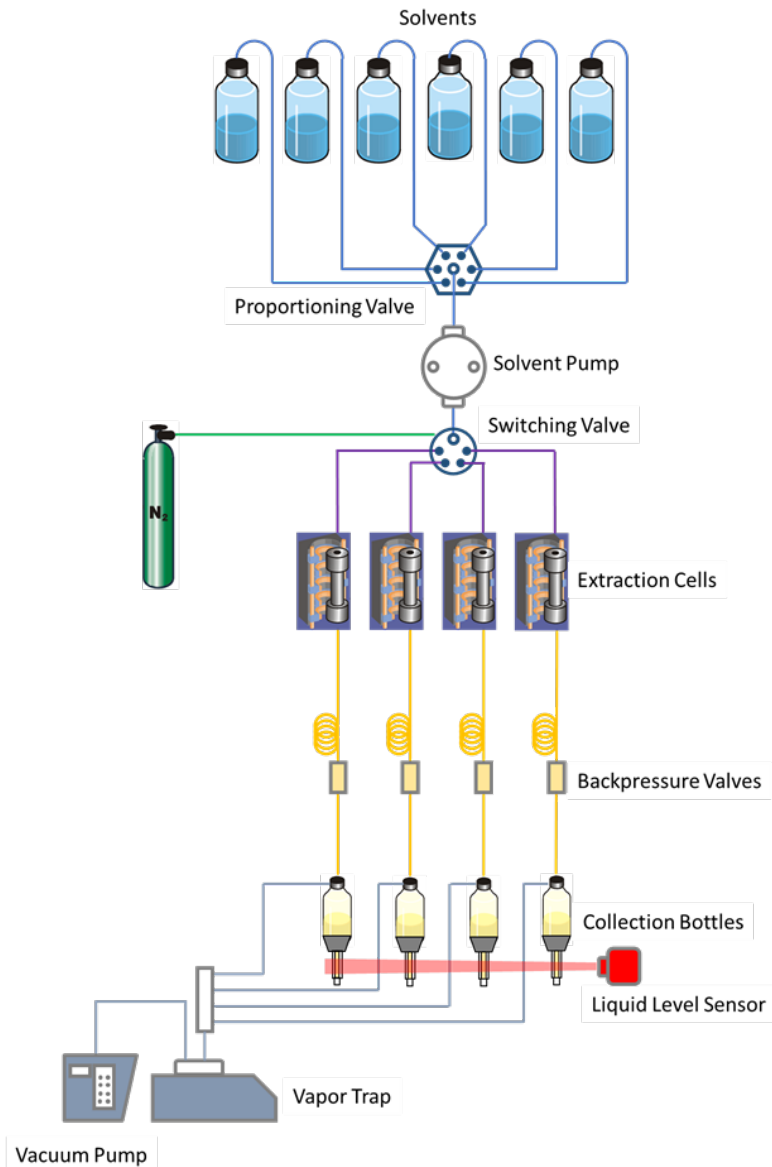

- Ability to blend up to 6 solvents
- Dynamic gas assisted extraction
- Integrated sample concentration/evaporation
- Collect and concentrate directly into an autosampler vial
- Smart automatic end point detection using machine learning
- Recover used solvents

24-h Total Workflow (Extraction + Evaporation)

Based on 10-mL cell extraction

Combined automated extraction and evaporation: 48 samples per day

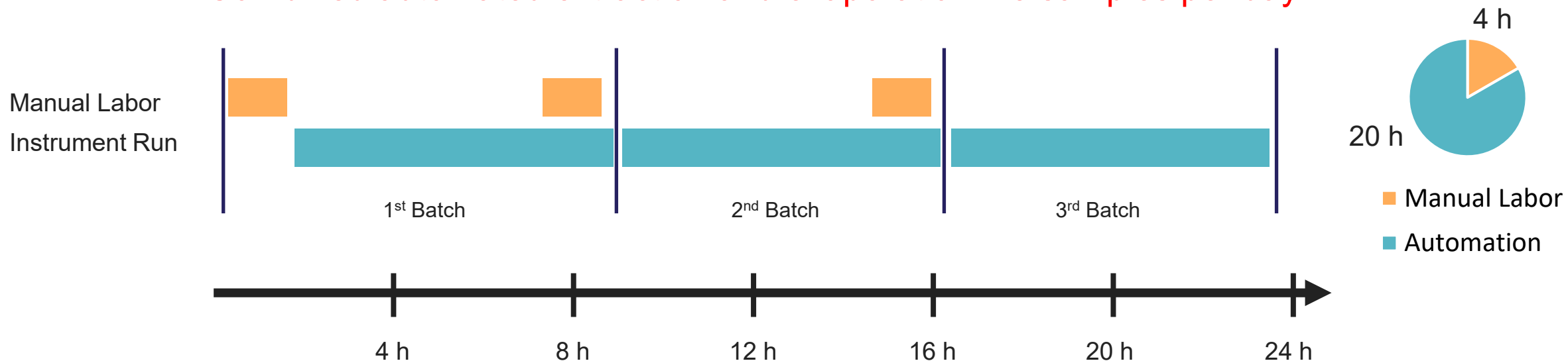

Traditional Automated Methods: 36 samples per day

5. Conceptual Device Data

 The world leader in serving science

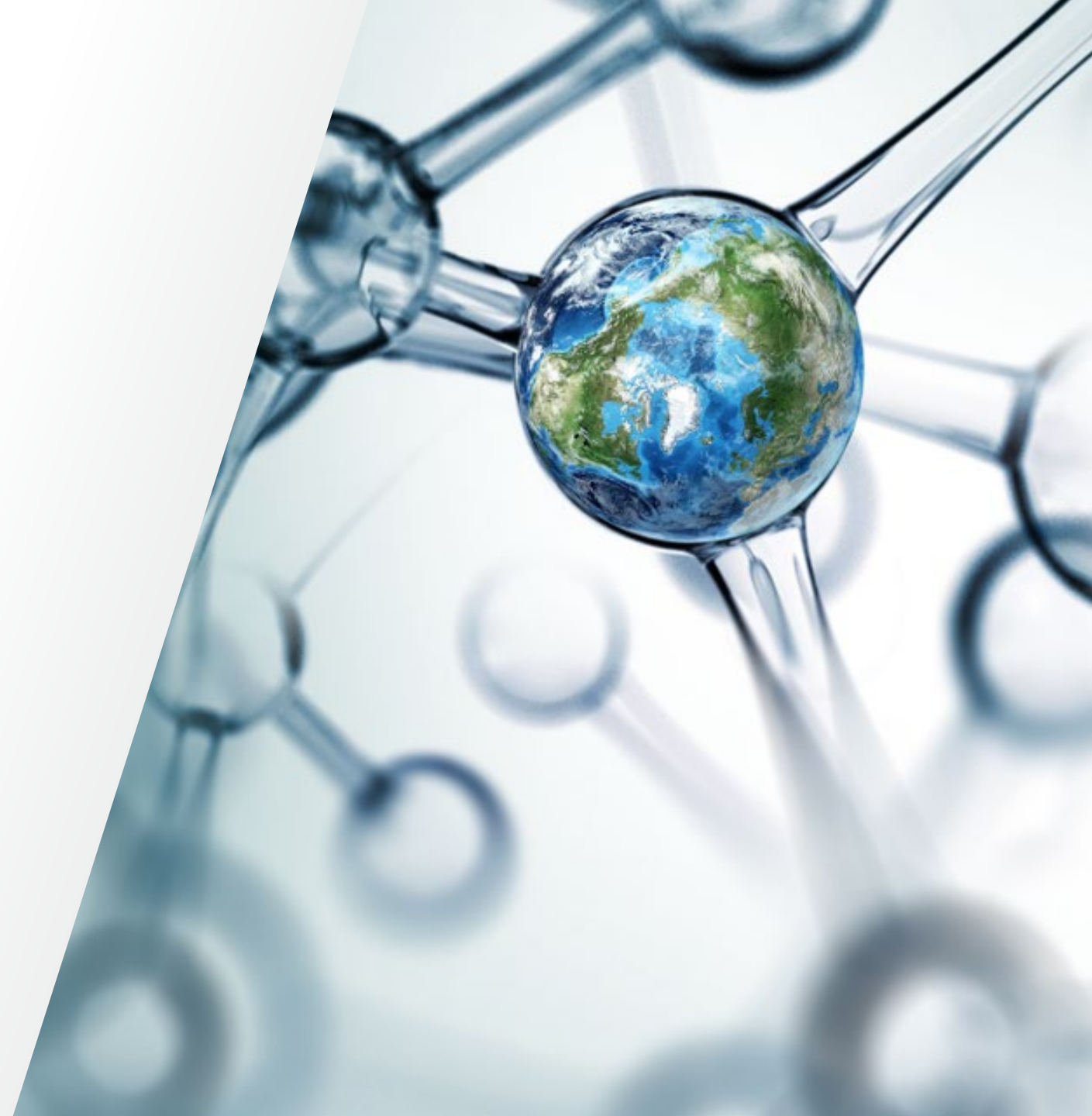

Device data – PAH recovery and reproducibility

PAHs prepared from soil samples

Compound	Average recovery (%) (10 mL cell, n = 12)	RSD	Average recovery (%) (10 mL cell, n = 12)	RSD
Naphthalene	78.7	1.1	79.5	4.9
Acenaphthylene	81.7	5.4	82.3	4.2
Acenaphthene	76.8	1.7	79.7	6.8
Fluorene	78.4	2.6	80.2	1.7
Phenanthrene	79.0	2.7	85.1	6.2
Anthracene	80.3	2.0	85.3	7.1
Fluoranthene	86.3	1.0	93.1	4.5
Pyrene	85.5	2.1	95.2	6.0
Benz[a]anthracene	97.6	2.0	99.8	3.0
Chrysene	86.8	0.9	98.3	4.6
Benzo[b]fluoranthene	81.4	12.9	103.3	1.6
Benzo[k]fluoranthene	80.6	13.3	103.0	1.7
Benzo[a]pyrene	92.1	1.6	104.7	1.5
Indeno[1,2,3- <i>cd</i>]fluoranthene	86.6	4.8	99.2	2.5
Dibenz[a,h]anthracene	83.9	6.7	96.6	1.7
Benzo[ghi]perylene	84.3	7.1	98.8	3.7

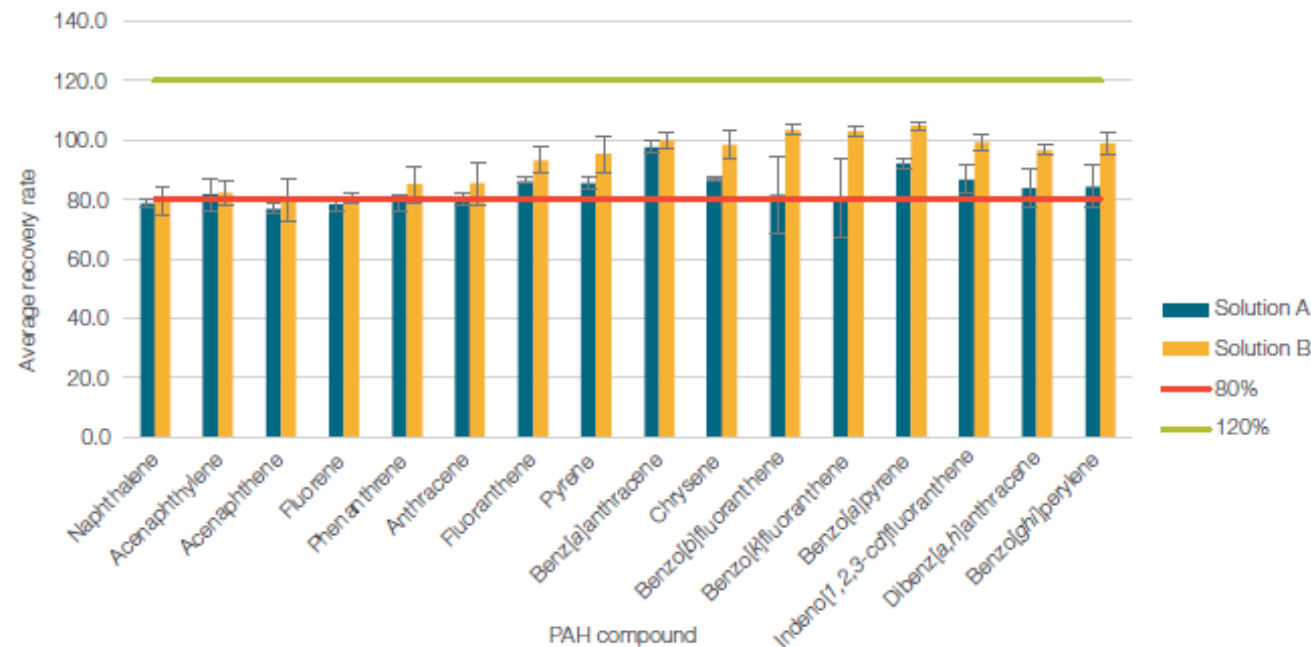

PAHs from certified samples

PAH compound	Certified value	Acceptance range	Average recovery and RSD (10 mL cell, n = 12)	
	µg/kg	µg/kg	Avg (n=12) µg/kg	RSD (n=12)
Naphthalene	494 ± 38	164 to 824	362	6.76
Acenaphthylene	630 ± 38	328 to 933	490	1.58
Acenaphthene	651 ± 64	141 to 1162	502	1.25
Fluorene	157 ± 19	10.7 to 303	140	3.07
Phenanthrene	290 ± 26	65.2 to 516	283	0.58
Anthracene	612 ± 51	173 to 1051	447	2.76
Fluoranthene	333 ± 25	119 to 547	349	0.95
Pyrene	202 ± 20	35.7 to 369	240	2.21
Benz[a]anthracene	329 ± 20	158 to 500	404	1.22
Chrysene	146 ± 12	49.8 to 241	168	4.45
Benzo[b]fluoranthene	69.9 ± 4.5	32.6 to 107	79	1.74
Benzo[k]fluoranthene	266 ± 21	95.0 to 437	251	1.41
Benzo[a]pyrene	223 ± 17	83.5 to 363	206	4.34
Indeno[1,2,3-cd]fluoranthene	88.8 ± 8.3	19.5 to 158	106	6.50
Dibenz[a,h]anthracene	193 ± 16	74.4 to 312	230	1.95
Benzo[ghi]perylene	224 ± 22	44.3 to 404	274	1.49

Device data – OCPs recovery and reproducibility

Organochlorine pesticides prepared from soil samples

Compound	Average recovery (%) (10 mL cell, n = 12)	RSD	Average recovery (%) (100 mL cell, n = 12)	RSD
α-BHC	87.7	3.7	93.3	6.6
γ-BHC	87.2	4.0	93.1	6.6
β-BHC	101.4	8.0	99.3	6.4
δ-BHC	95.3	5.6	98.1	7.0
Heptachlor	91.5	3.5	87.3	6.1
Aldrin	90.1	4.9	90.3	6.6
Heptachlor epoxide	92.9	3.8	95.2	7.1
trans-Chlordane	94.3	4.1	96.9	7.3
cis-Chlordane	101.3	3.8	97.7	7.2
4,4'-DDE	97.4	2.8	96.0	7.4
Endosulfan I	98.5	2.8	95.4	7.9
Dieldrin	98.4	3.0	94.8	7.4
Endrin	103.2	5.9	102.2	8.5
4,4'-DDD	103.4	3.6	91.5	7.6
Endosulfan II	101.5	4.1	97.4	7.7
4,4'-DDT	96.9	2.5	94.9	8.3
Endrin aldehyde	103.2	4.5	88.0	9.0
Methoxychlor	108.0	4.1	96.5	6.8
Endosulfan sulfate	100.7	2.9	102.2	6.7
Endrin ketone	99.7	1.9	97.1	6.9

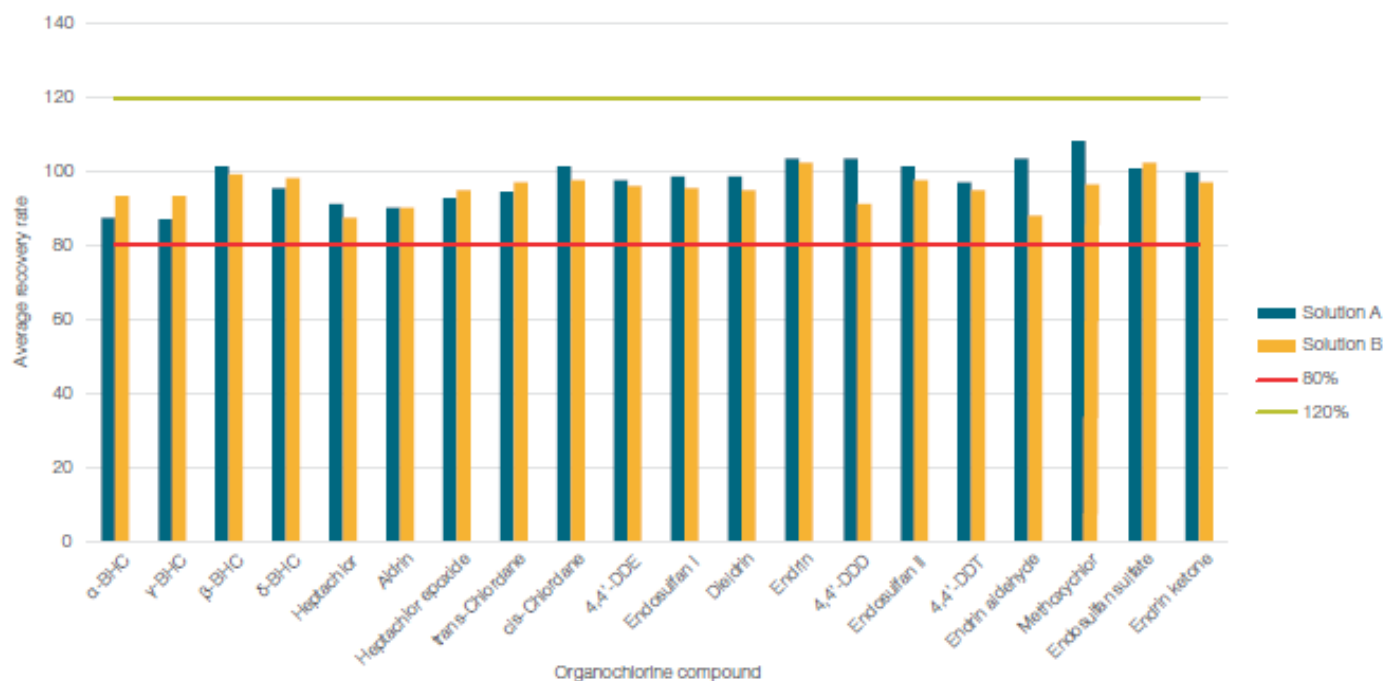

Questions

