

High Performance Liquid Chromatograph for Ion Analysis

# Ion Chromatograph



# Total Support for Ion Analysis

---



In 1986, Shimadzu developed its first ion chromatograph. Shimadzu has been accumulating vast amounts of ion analysis research and data, and has grown to become a world-leading ion chromatograph manufacturer, developing both suppressor and non-suppressor systems.

When using ion chromatographs for the measurement of regulated compounds, instrument performance and analysis conditions must be suited to the objectives. In recent years, a wide assortment of detection methods has been adopted. In addition to electrical conductivity detection methods, there are combinations of UV absorption detection and post-column derivatization. Accordingly, a degree of perfection is now required of systems, including the basic performance of the detector units, as well as optimization of the reaction parts.

Shimadzu has introduced not only ion chromatographs but also general-purpose instrumental analysis methods for inorganic ions.

## Environmental Field

Tap water  
Drain water  
River water  
Factory drainage  
Soil water

## Pharmaceutical and Food Fields

## General Ion Analysis

Research  
Development  
Quality control

# Selecting a Suppressor/Non-suppressor System

## Anion Analysis

In anion analysis, the mobile phase composition and separation vary depending on whether or not a suppressor is used. In addition to the sensitivity required and the sample concentration, running costs are another issue when selecting a system.

|  | Non-Suppressor                    | Suppressor         |
|--|-----------------------------------|--------------------|
| Detection Sensitivity                      | Good                              | Excellent          |
| Degree of Freedom in Separation Conditions | Excellent                         | Good               |
| Mobile Phase Composition                   | Excellent<br>(acidic to alkaline) | Good<br>(alkaline) |
| Additives                                  | Excellent                         | Good               |
| Temperature Control                        | Excellent                         | Excellent          |
| Calibration Curve                          | Excellent                         | Good               |
| Running Costs                              | Excellent                         | Good               |
| Maintenance                                | Excellent                         | Good               |

### Detection sensitivity

Generally calculated from the S/N ratio and standard deviation, this term is used in the concentration region in which noise affects the quantitative results. Suppressor systems are effective for improving the quantitative accuracy in this concentration region, as they provide peak signal amplification. However, *this amplification is only valid for anion analysis.*

### Degree of freedom in separation investigations

As with HPLC, ion separation and detection take advantage of the target substance's characteristics. In non-suppressor systems, analytical conditions can be changed to suit the sample characteristics, as there are none of the limits on mobile phase when utilizing a suppressor.

### Mobile phase composition

#### Anion analysis

The mobile phase in a suppressor system must be a basic solution, but with non-suppressor systems, a wide variety of solutions can be used, ranging from acidic to basic. With organic acids, the ion valence changes with the pH of the mobile phase, and this can dramatically affect the elution position.

#### Cation analysis

With non-suppressor systems, the acidic mobile phase alternatives are extensive, and multiple acids can even be mixed to improve the separation. Furthermore, the separation arrangement is also extensive as a variety of additives can be used, including organic solvents.

### Additives

Reagents can be added to the mobile phase, with the objective of improving specific ion separation. With a non-suppressor system, the possibilities are endless, including crown compounds to improve the separation of Na and NH<sub>4</sub>, and a variety of reagent additives to render the mobile phase composition similar to the sample matrix.

### Temperature control

With ion chromatographs from other companies, column and detector temperature control has largely been overlooked. Yet varying the temperature is an effective means of controlling elution time for substances with differing ion valences and hydrophobic regions. Heating performance can be said to be an important aspect of ion chromatography.

### Calibration curve

With non-suppressor systems, the calibration curve is linear, since detection occurs under the same mobile phase conditions as separation. In contrast, with suppressor systems, since the mobile phase is changed to a weak acid or water, and the pH changes in accordance with changes to the ion concentration in the sample, with organic acids and amines, the extent of ionization varies, producing a nonlinear calibration curve.

### Running costs and Maintenance

Maintenance is indispensable in order to maintain the performance of precision analytical instruments. In addition to parts to maintain hardware performance, consumables must also be considered. With non-suppressor systems, attention to suppressor parts is completely unnecessary, an advantage in terms of both maintenance and running costs.

# Cation Analysis

With cation analysis, ions can be separated with an acidic mobile phase in both suppressor and non-suppressor systems. However, non-suppressor systems are advantageous for separation investigations as they allow the mobile phase composition to be arranged in a variety of ways.

|  | Non-Suppressor                                  | Suppressor |
|--|---|------------|
| Detection Sensitivity                      | Excellent                                       | Excellent  |
| Degree of Freedom in Separation Conditions | Excellent                                       | Good       |
| Mobile Phase Composition                   | Excellent<br>(Multiple components can be mixed) | Good       |
| Additives                                  | Excellent                                       | Good       |
| Temperature Control                        | Excellent                                       | Excellent  |
| Calibration Curve                          | Excellent                                       | Good       |
| Running Costs                              | Excellent                                       | Good       |
| Maintenance                                | Excellent                                       | Good       |

## What Is the Optimal Elemental Analysis Method?

AA and ICP are also available for cation analysis. It is recommend to select an appropriate analytical method according to the purpose such as the type of sample, the number of samples, elements, concentration, etc.

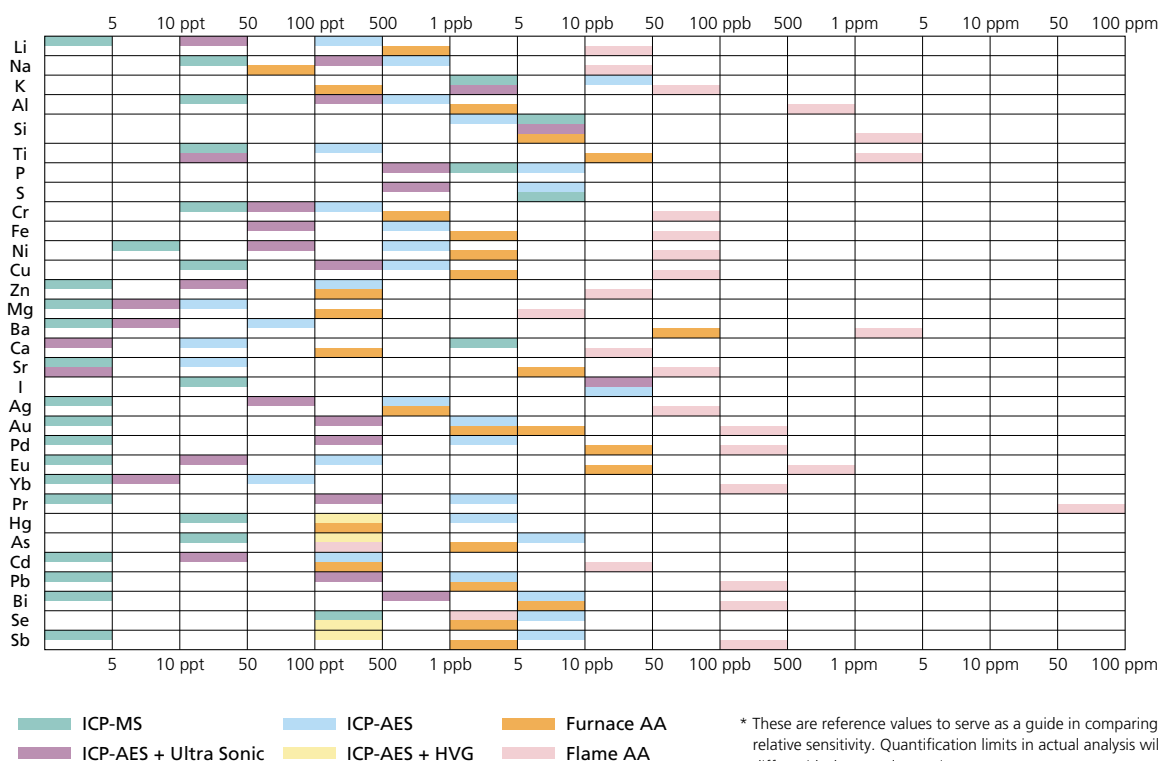

# Anion Analysis System

## HIC-ESP — Provides stable functionality even over long periods of use

The HIC-ESP is a anion suppressor ion chromatograph with built-in electrochemical suppressor, boasting the same low carryover and excellent injection precision characteristic of Shimadzu HPLCs to bring you highly-reliable results. The HIC-ESP is suitable for applications in a wide range of fields including environmental science, medicine, chemistry and food science.

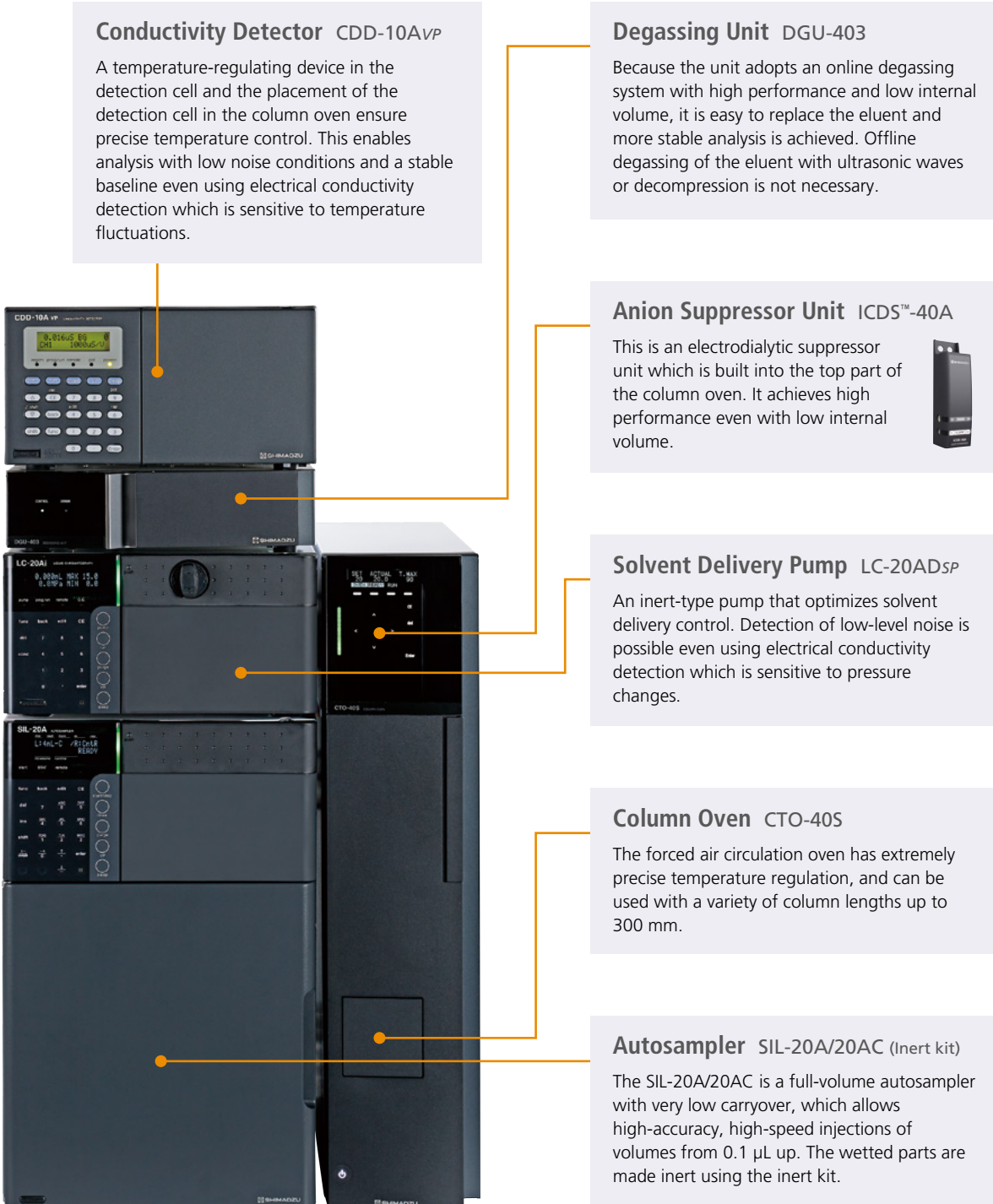

**Conductivity Detector CDD-10AVP**  
A temperature-regulating device in the detection cell and the placement of the detection cell in the column oven ensure precise temperature control. This enables analysis with low noise conditions and a stable baseline even using electrical conductivity detection which is sensitive to temperature fluctuations.

**Degassing Unit DGU-403**  
Because the unit adopts an online degassing system with high performance and low internal volume, it is easy to replace the eluent and more stable analysis is achieved. Offline degassing of the eluent with ultrasonic waves or decompression is not necessary.

**Anion Suppressor Unit ICDS™-40A**  
This is an electrochemical suppressor unit which is built into the top part of the column oven. It achieves high performance even with low internal volume.

**Solvent Delivery Pump LC-20ADSP**  
An inert-type pump that optimizes solvent delivery control. Detection of low-level noise is possible even using electrical conductivity detection which is sensitive to pressure changes.

**Column Oven CTO-40S**  
The forced air circulation oven has extremely precise temperature regulation, and can be used with a variety of column lengths up to 300 mm.

**Autosampler SIL-20A/20AC (Inert kit)**  
The SIL-20A/20AC is a full-volume autosampler with very low carryover, which allows high-accuracy, high-speed injections of volumes from 0.1 µL up. The wetted parts are made inert using the inert kit.

## Anion Suppressor Unit ICDS-40A

### Achieves high sensitivity, reliability and robustness

With a unique design where the eluent flow path bends back around, combined with optimized dialytic, the new ICDS-40A anion suppressor unit achieves higher efficiency and stable suppressing while maintaining a small internal volume (patent pending).

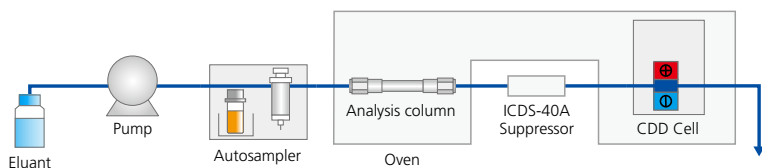

Flow-line diagram for the HIC-ESP

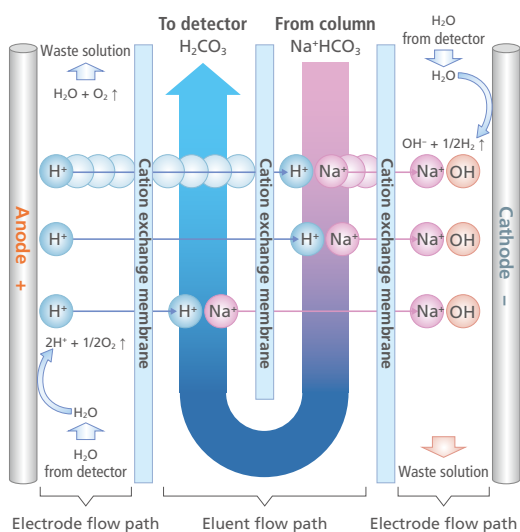

Structure and principles behind the ICDS-40A

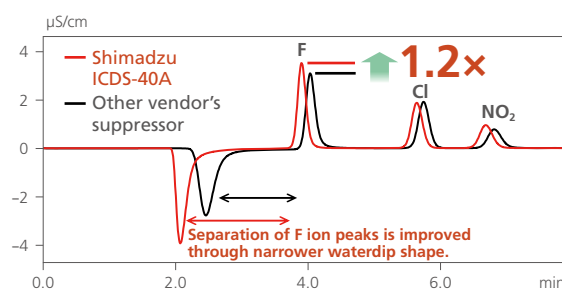

The plot on the right shows peak response from analysis of a standard solution after each 100 injections of river water. Even after a long, continuous analysis of the sample, the peak intensity for each ion is stable. The excellent ion exchange function of the ICDS-40A is supported by the robustness of the HIC-ESP over a long analysis.

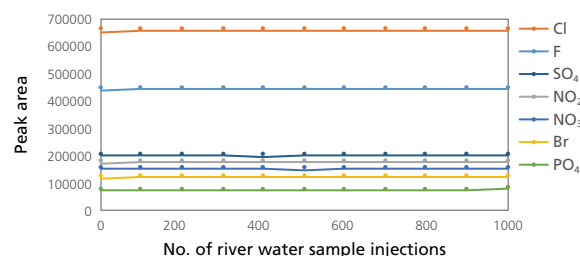

## HIC-SP —Suppressor systems, aiming for further sensitivity

The Shimadzu suppressor is a proprietary cartridge type with electrodes at both ends. Cartridge type reduce the background electric conductivity by using ion-exchange groups to trap eluent counter ions within a column packed with an ion-exchange polymer. Because separate processes are used for analysis and regeneration, there is no noise from regeneration, which enables low-noise operation. Continuous analysis is possible by alternately replacing the cartridges.

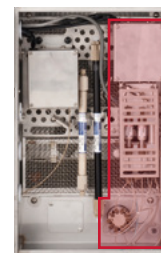

Note: Anion analysis is also possible with the non-suppressor type. Contact a Shimadzu representative for details.

# Cation Analysis System

## HIC-NS —Non-suppressor systems, aiming to be simpler, with high sensitivity

The mobile phase conductivity is affected by temperature changes and solvent delivery pump pressure variations, which can lead to baseline noise and drift. With suppressors, noise is reduced by reducing mobile phase conductivity, the source of these problems. With non-suppressor systems, however, this problem must be dealt with by improving basic hardware performance. Shimadzu accomplishes this using its proprietary high basic performance. This includes pulse-free solvent delivery, which suppresses pressure variations during solvent delivery to a bare minimum, and double temperature control, featuring detector cells equipped with thermal control functionality arranged within the column oven.

### Solvent Delivery Pump

LC-20AD<sub>SP</sub>

With the pulse-free solvent delivery pump, which is capable of solvent delivery at 100 nL/min to 10 mL/min, conductivity detection, which does not require suppressors, can be performed.



### Autosampler SIL-20A/20AC

The total-volume injection system based on plunger pump measurement, which is capable of high-speed injection and high accuracy from 0.1  $\mu$ L.

### Column Oven CTO-20A/20AC

The column oven features forced air-circulation, which has an established reputation for HPLC column temperature control. Furthermore, thanks to the electronic cooling function, column temperature can be controlled from an ambient temperature of  $-15$   $^{\circ}$ C. In addition to columns, this large-capacity oven can simultaneously accommodate a suppressor/non-suppressor conductivity detector cell assembly.

### Forced air-circulation system

This temperature control system controls the temperature using a fan installed at the back of the column to provide forced air circulation within the oven. This is ideal for high-accuracy thermal control of columns and detector cells arranged within the oven, as well as for post-column reaction parts.



# System Variations

## Dual Flow-Line Analysis System

With automatic switching of the sample injection valves, a sample loop with 2 flow lines is consolidated into one. Simultaneous analysis is performed by adding sample to the 2 sample loops with a single sample injection. This system is ideal for routine analysis of anions and cations as in tap water quality analysis. A UV detector can also be used when the anion suppressor system is used.

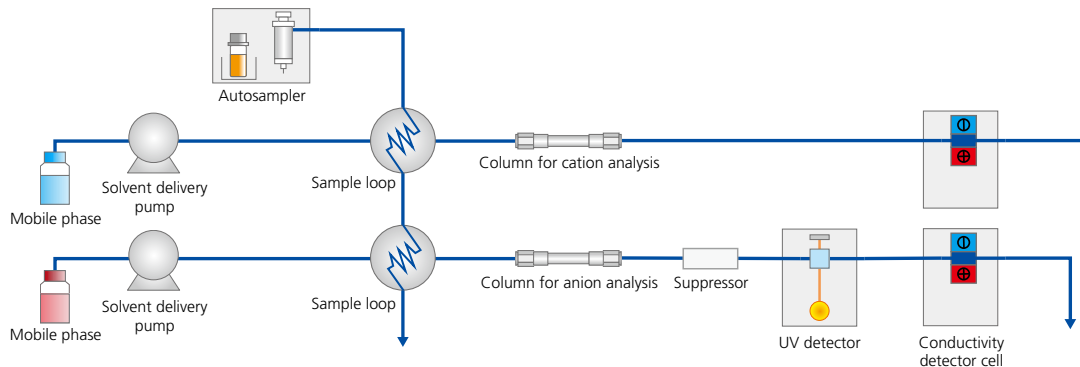

Flow-line diagram for the dual flow-line analysis system

## CDD-10A<sub>VP</sub> conductivity detector with a 2-channel detector configuration

Adding the optional dual kit NS (non-suppressor system) in the main unit adds non-suppressor (NS) system detector functionality. The result is a 2-channel detector equipped with 2 detector cell units.

## Combustion Ion Chromatography System

This system is used to confirm the absence of halogen in electrical equipment and electronic components, and to measure sulfur compounds in chemical materials. Plastics, electronic materials and other solid samples are incinerated. The gases generated by incineration are captured by an absorbing liquid, which is then analyzed by an ion chromatograph for fluoride, chloride, and other halogens, and for sulfur and other ions.

### Incineration System

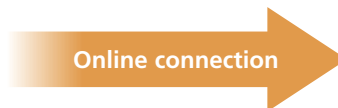
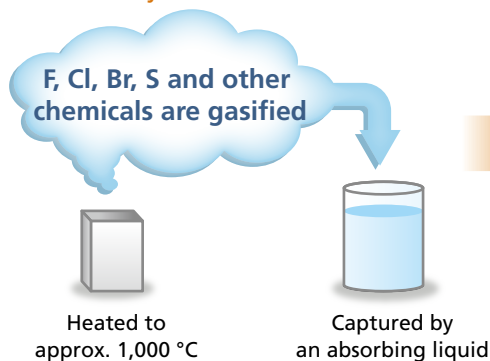

## Nexera™ Organic Acid Analysis System

This system is ideal for organic acid analysis of samples with matrices, e.g. food products or fermented samples. Combining ion-exclusion chromatography with Shimadzu's unique detection technique (pH buffered electric conductivity detection), the system excels in both selectivity and sensitivity.

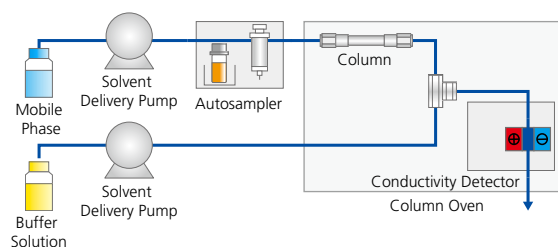
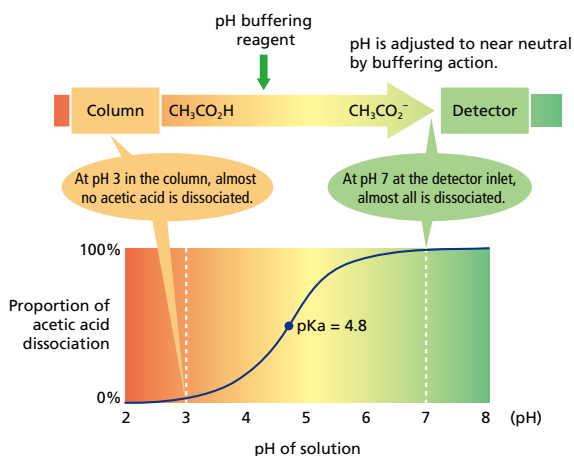

## Achieves high selectivity and sensitivity

Culture mediums and food samples contain not only organic acids but also various impurities. With UV detection, the absorbance varies depending on the type of organic acid, so quantification may be difficult due to variations in sensitivity or the effects of impurities. The organic acid system is a highly selective, high-sensitivity system. In this system, organic acids are separated using ion exclusion chromatography via Shimadzu's unique detection technique (pH buffered electric conductivity detection). Then, a pH buffering reagent is continuously added to the column eluate in order to keep the pH level at around neutral and dissociate organic acids in order to detect electric conductivity.

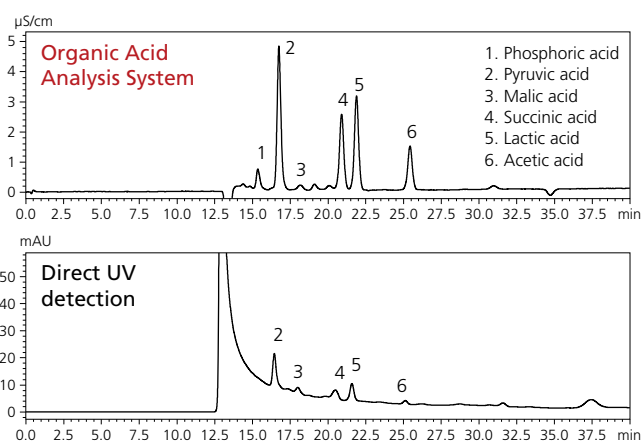

## Specialty of the Shimadzu Post-Column System

A high-efficiency reaction is a key feature of post-column systems. To ensure high-accuracy thermal reaction control, Shimadzu adopted a chemical reaction chamber (CRB-40) and column oven (CTO-40C/40S) featuring a forced air-circulation system that enjoys an established reputation in HPLC. Each of the special piping parts was designed separately to optimize the reaction system (Japanese Patent #4082309).

# Complete Support and Ease-of-use Throughout Your Workflow

Manage analysis, data processing and reports all from LabSolutions™

Settings for analysis parameters, continuous analysis, auto-shutdown, data processing, and report creation can all be managed from LabSolutions analysis software. Data integrity can be handled with the addition of LabSolutions DB and LabSolutions CS.



Simple, all-in-one checks of calibration curves and peak integration with the results browser function

① Drag and drop batch files to be processed into the results browser screen

② Filter and display standard/control samples or unknown samples

③ Check statistical results for areas or retention times of each peak in the table

④ Scroll between chromatograms to check results with mouse clicks or arrows on the keyboard

Data explorer

Peak integration parameter editing

| Ret. Time | Area         | Height       | Conc. (mg/L) | Accuracy (%) | Deviation | QC Check Results  |
|-----------|--------------|--------------|--------------|--------------|-----------|-------------------|
| 2.128     | 78.812       | 12.172       | 1.201        | 105.1        | 0.201     |                   |
| 2.156     | 144.642      | 20.172       | 1.999        | 101.0        | 0.202     |                   |
| 2.412     | 296.795      | 47.899       | 4.201        | 101.0        | 0.201     |                   |
| 2.857     | 224.102      | 35.202       | 3.200        | 100.0        | 0.200     |                   |
| 2.810     | 80.026       | 12.812       | 0.820        | 100.0        | 0.200     | Upper Range Limit |
| 2.810     | 178.154      | 27.412       | 2.200        | 100.0        | 0.200     |                   |
| 2.815     | 118.168      | 20.827       | 1.162        | 100.0        | 0.200     |                   |
| 2.854     | 175.245      | 27.547       | 2.192        | 100.0        | 0.200     |                   |
| 3.021.79  | 51.17476     | 8.181381     | 0.5272913    | 0.1372613    | 43.131719 |                   |
| 4.646     | 296.795      | 47.899       | 4.201        | 100.1        | 0.202     |                   |
| 7.481     | 83.058       | 13.012       | 0.870        | 98.8         | 0.200     |                   |
| 2.011681  | 82.887268279 | 14.738468279 | 1.32271      | 0.1372613    | 0.20017   |                   |

Automatic judgments on analytical results

Results can be checked and errors or outliers detected much more quickly, with the software automatically judging calibration curve validity, maximum and minimum limits for sample values, etc.

Table of quantitative results

Chromatogram display

Calibration curve information

Quantitative results browser

Easily produce reports and summaries

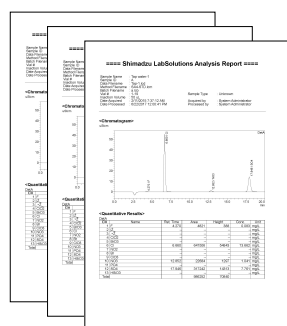

Reports with detailed information about individual sample data

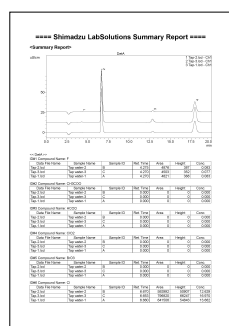

Summary report compiling data from multiple reports

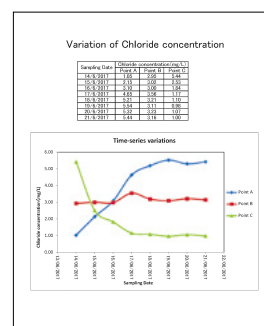

Multi-data report with graphs of data from multiple analyses

The report function allows the automatic creation of individual analysis or summary reports, as well as multi-data reports\* which can produce graphs and handle other data processing for results from multiple samples. The data can be automatically imported into a premade template, reducing the time needed to write reports and reducing the possibility of errors.

\* Multi-data reports are an optional LabSolutions DB/CS function

ICDS, Nexera and LabSolutions are trademarks of Shimadzu Corporation or its affiliated companies in Japan and/or other countries.



Shimadzu Corporation

[www.shimadzu.com/an/](http://www.shimadzu.com/an/)

**For Research Use Only. Not for use in diagnostic procedures.**

This publication may contain references to products that are not available in your country. Please contact us to check the availability of these products in your country.

Company names, products/service names and logos used in this publication are trademarks and trade names of Shimadzu Corporation, its subsidiaries or its affiliates, whether or not they are used with trademark symbol "TM" or "®".

Third-party trademarks and trade names may be used in this publication to refer to either the entities or their products/services, whether or not they are used with trademark symbol "TM" or "®".

Shimadzu disclaims any proprietary interest in trademarks and trade names other than its own.

The contents of this publication are provided to you "as is" without warranty of any kind, and are subject to change without notice. Shimadzu does not assume any responsibility or liability for any damage, whether direct or indirect, relating to the use of this publication.