

Now sold under the  
Thermo Scientific brand

**Thermo**  
SCIENTIFIC

# Determination of Trace Anions in High-Nitrate Matrices by Ion Chromatography

## INTRODUCTION

There is a need for a reliable method to determine trace anions in samples containing high concentrations of nitrate ion. For example, chloride contamination present in the nitric acid used to etch wafers can significantly compromise the yield and reliability of semiconductors.<sup>1</sup> Traditional wet chemical methods are not sensitive and reliable enough for these demanding trace-level anion determinations. A direct injection method has been developed to address this need using a microbore IonPac® AS15 column. Conditions are optimized for sensitive determination of anions at trace levels with the EG40 Eluent Generator. This application note describes the theoretical background, setup, and analytical procedure for a method to determine chloride, sulfate, and phosphate to low- $\mu\text{g/L}$  (ppb) levels in 0.7% (v/v) nitric acid and other matrices that contain high concentrations of nitrate ion.

## EQUIPMENT

Dionex DX-600 Ion Chromatography System consisting of:

- GS50 Gradient Pump
- CD25 Conductivity Detector
- LC20 Chromatography Enclosure equipped with Rheodyne Model 9126 injector, PEEK, rear-loading (P/N 56995)

BF2 Column Switching Valve Kit (optional, for pressurized reservoir sample loading; P/N 44187)

EG40 Eluent Generator with EGC-KOH Cartridge

Pressurized Sample Vessel (optional; P/N 37460)

SRS® External Regenerant Installation Kit (P/N 38018) with one additional 4-L bottle or Gas Assisted Regeneration Kit (P/N 056886)

PeakNet® Chromatography Workstation

## REAGENTS AND STANDARDS

Deionized water (DI H<sub>2</sub>O), Type I reagent-grade, 17.8 M $\Omega$ -cm resistance or better

Sodium hydroxide 50% w/w aqueous solution (Fisher Scientific) or Potassium hydroxide 45% w/w aqueous solution (Fisher Scientific)

Chloride standard 1000 mg/L, 100 mL (Dionex, P/N 37159)

Sulfate standard 1000 mg/L, 100 mL (Dionex, P/N 37160)

Phosphate standard 1000 mg/L, 100 mL (ULTRA Scientific, VWR P/N ULICC-005)

Dionex Combined Five Anion Standard, 100 mL (fluoride, 20 mg/L; chloride, 30 mg/L; nitrate 100 mg/L; phosphate, 150 mg/L; sulfate, 150 mg/L; optional)

## CONDITIONS

Columns: IonPac® AS15 Analytical, 2 × 250 mm (P/N 53941)

IonPac AG15 Guard, 2 × 50 mm (P/N 53943)

Trap Column: ATC-1 Trap, 4 mm (P/N 37151)  
ATC Trap, 2 mm (P/N 43131)

Eluent: Potassium hydroxide (EG40 as the source)

Temperature: Ambient  
 EG40 Offset  
 Volume: 0 µL  
 Pump Program:

Time (min)	Flow (mL/min)	A (%)	Inj. Valve	Column Valve	KOH Conc. (mM)	Comments
0.00	0.20	100	Load	A*	48	48 mM KOH; RDM "On"; Load Sample Loop
4.30	0.20	100	Load	B**	48	RDM "Off"
5.00	0.20	100	Inject	B	48	Inject
20.00	0.20	100	Inject	B	48	End analytical separation
20.01	0.20	100	Inject	B	100	Begin Cleanup step
40.00	0.20	100	Inject	B	100	End Cleanup step
40.01	0.20	100	Inject	B	48	Begin equilibra- tion 48 mM
60.00	0.20	100	Inject	B	48	End

\*A = Inject  
 \*\*B = Load

Eluent Flow Rate: 0.2 mL/min  
 Detection: Suppressed conductivity,  
 ASRS® ULTRA AutoSuppression®  
 External Water Mode or Gas  
 Assisted Recycle Mode  
 SRS Current  
 Setting: 50 mA  
 Expected  
 Background  
 Conductivity: 1 µS (48 mM KOH)  
 Expected System  
 Backpressure: 17.2 MPa (2500 psi)  
 Sample Volume: 1 µL

## PREPARATION OF SOLUTIONS AND REAGENTS

### Standard Solutions

#### Stock Anion Standard Solution (1000 mg/L)

Use commercially available anion standards or prepare 1000-mg/L standards of each ion by dissolving the appropriate amount of its salt in 1000 mL of deionized water (see Table 1). Dry the salts at 105 °C prior to weighing.

**Table 1. Amounts of Compounds Used to Prepare 1 L of 1000-mg/L Ion Standards**

Anion	Compound	Mass (g)
Cl <sup>-</sup>	Sodium chloride (NaCl)	1.648
SO <sub>4</sub> <sup>2-</sup>	Sodium sulfate (Na <sub>2</sub> SO <sub>4</sub> )	1.522
NO <sub>3</sub> <sup>-</sup>	Sodium nitrate (NaNO <sub>3</sub> )	1.371
PO <sub>4</sub> <sup>3-</sup>	Potassium phosphate, monobasic (KH <sub>2</sub> PO <sub>4</sub> )	1.433

### Composite Standard Solution

Composite standards at lower analyte concentrations are prepared from 1000-mg/L standards. Select a range similar to the expected analyte concentrations in the samples. Working standards containing less than 100 µg/L anions should be prepared daily.

### ATC Regeneration Solution

#### 2 M Sodium Hydroxide

Dilute 160 g of 50% (w/w) sodium hydroxide with degassed, deionized water (with a specific resistance of 17.8 MΩ-cm or greater) to a final weight of 1080 g in an eluent bottle. Avoid the introduction of carbon dioxide from air. *Note: 2 M potassium hydroxide can be used instead of 2 M sodium hydroxide. Preparation is the same as above except that 249 g of 45% potassium hydroxide is used for a final weight of 1090 g.*

### Sample Preparation

#### 0.7% Nitric Acid (1:100 Dilution of 70% Nitric Acid)

Pour 99 mL of deionized water into a clean Teflon® sample container. While in a fume hood, very slowly and carefully add 1.000 mL (1.42 g) of 70% concentrated nitric acid to the deionized water. (Always add acid to water, not water to acid.) Gently mix the acid with the water and allow the solution to cool to room temperature.

*Caution: Use extreme care when handling nitric acid. Avoid all contact with exposed skin. The use of eye protection, proper gloves, and a fume hood is an absolute necessity. Consult the Material Safety Data Sheet (MSDS) for more specific details about protective equipment, reactivity, and health effects.*

## Calibration

Prepare at least three different calibration standards at different concentrations of the working standard. Select a range similar to the expected concentrations in the samples. The method of standard additions (adding one or more increments of a standard solution to sample aliquots of the same size) can be used to counteract the matrix effect of the concentrated acid.<sup>2</sup> Calibration standards are added to the deionized water used to dilute the concentrated nitric acid from 70% (w/w) to 0.7% (v/v). The following formula can be used to calculate concentrations for dilutions:

$$\left( \begin{array}{c} \text{Concentration} \\ \text{of stock} \\ \text{solution,} \\ \text{mg/L} \end{array} \right) \cdot \left( \begin{array}{c} \text{Volume} \\ \text{of stock} \\ \text{solution,} \\ \text{mL} \end{array} \right) = \left( \begin{array}{c} \text{Concentration} \\ \text{of dilute} \\ \text{standard,} \\ \text{mg/L} \end{array} \right) \cdot \left( \begin{array}{c} \text{Volume} \\ \text{of dilute} \\ \text{standard,} \\ \text{mL} \end{array} \right)$$

## SYSTEM PREPARATION AND SET-UP

This section describes the procedure for the initial installation and start-up of the ASRS ULTRA Anion Self-Regenerating Suppressor, ATCs, and EGC-OH EluGen® cartridge. Prepare the ASRS for use by hydrating the eluent and regen chamber with 0.2 N H<sub>2</sub>SO<sub>4</sub>. Let the ASRS rest for at least 20 min before pumping eluent through the eluent chamber. (For more information on ASRS operation, consult the *Quickstart Instructions for the ASRS ULTRA*, Document No. 031368.)

Prepare the ATCs for use by rinsing with 200 mL of 2 M KOH or 2 M NaOH at 2.0 mL/min. This can be done offline without the GS50 pump by pressurizing an eluent bottle with helium at 34.5 kPa (5 psi). Then rinse the two ATCs with deionized water at 2.0 mL/min for 20 min. Install the EGC-OH EluGen cartridge according to the instructions in the *Operator's Manual for the EG40 Eluent Generator System* (Document No. 031373). Place the 4-mm ATC between the GS50 outlet and the EGC-KOH cartridge inlet and the 2-mm ATC between the EG40 degas unit outlet and the injection valve inlet, as shown in Figure 1.

Configure the system for external water with an External Regenerant Installation Kit or Gas-Assisted Regeneration Kit. For the conventional external water mode, configure the 4-L pressurizable reservoir as shown in Figure 2 for supplying water to the "Regen In" port of the ASRS. It is advisable to use two 4-L bottles plumbed in tandem to ensure uninterrupted external water delivery. Fill the reservoirs with deionized water with a specific resistance of 10 MΩ-cm or greater.

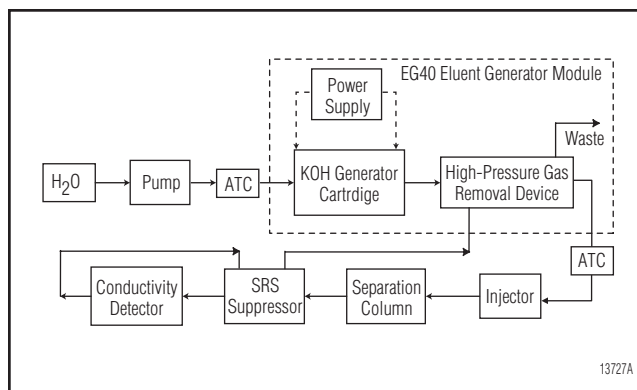

Figure 1. An ion chromatography system using an EG40 Eluent Generator.

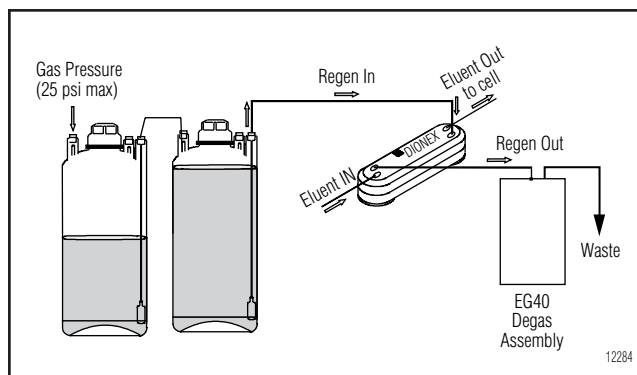

Figure 2. AutoSuppression External Water Mode using the pressurized water delivery system.

For the Gas Assisted Recycle Mode, connect the "Regen In" line (shorter tubing from the tee) to the SRS's "Regen In" port. Connect the line from the "Cell-Out" on the conductivity cell to the "From-Cell" line (longer tubing from the tee). Connect a gas line to the regulator. Compressed air can be used in place of helium or nitrogen if it is purified with suitable traps to remove moisture, hydrocarbons, carbon dioxide, and other particulate matters. (For more information, see the *SRS Gas-Assisted Regeneration Kit Installation and Use Instructions*, Document No. 031665-02.)

Make a 1-μL sample loop by cutting a 7.9 cm portion of the red 0.005-in. (0.125-mm) i.d. PEEK tubing. If a different loop or tubing with a different internal diameter is needed, refer to Table 2 to calculate the length needed. The volume of a loop can be verified by measuring the weight difference between the sample loop filled with deionized water and the empty loop. The inside diameter of tubing varies by as much as 20% (for example, 0.010 ± 0.002 in.).

**Table 2. Volume per Unit Length for Various Tubing Internal Diameters**

Material	Color	Internal Diameter		Estimated Volume ( $\mu\text{L}/\text{cm}$ )
		Inches	Millimeters	
PEEK	Red	0.005	0.125	0.126
PEEK	Black	0.010	0.250	0.506
PEEK	Orange	0.020	0.500	2.022
PEEK	Green	0.030	0.750	4.550

Connect the columns and suppressor to the six-port Rheodyne valve in the IC system by using 0.005-in. (0.125-mm) tubing. Keep the lengths of connecting tubing as short as possible to minimize system void volume. This will ensure efficient 2-mm column operation. Carefully use a razor blade or plastic tubing cutter to ensure that the surfaces of the tubing cuts have straight, smooth surfaces. Irregularity on the surface of a tubing end can result in unwanted additional dead volume.

### **SYSTEM OPERATION**

There are two options for operating the ASRS for low noise: external water mode or gas-assisted recycle mode.

#### **External Water Mode**

For external water mode, adjust the reservoir pressure from 0 to 172 kPa (0 to 25 psi) to deliver external water regenerant of 5 to 7 mL/min before applying current to the ASRS. Ensure that the reservoir cap is sealed tightly. Turn the power on to supply current to the ASRS; the flow rate will drop to about 0.7 mL/min due to gas formation in the regenerant. Check to see that bubbles are forming in the ASRS to verify that water from the regenerant channels is being electrolyzed.

Turn on the gradient pump flow to begin the flow of eluent through the system. If the system backpressure is below 14 MPa (2000 psi), add a portion of yellow PEEK 0.003-in. (0.075-mm) tubing between the outlet of the degas assembly in the EG40 and the inlet of the injection valve. Confirm that there are no leaks in the chromatographic pathway. (For more information, consult the *Operator's Manual for the EG40 Eluent Generator System*, Document No. 031373.)

#### **Gas-Assisted Recycle Mode**

Turn on the gradient pump flow to begin the flow of eluent through the system. If the system backpressure is below 14 MPa (2000 psi), add a portion of yellow PEEK 0.003-in. (0.075-mm) tubing between the outlet of the degas assembly in the EG40 and the inlet of the injection valve. Apply 10–15 psi to the "Regen In" port of the ASRS. A mixture of gas and liquid will be observed exiting the "Regen Out" port. Turn on the power to supply current to the ASRS; the gas flow rate across the regenerant chamber will be about 100 mL/min at a set pressure of 10–12 psi.

#### **Equilibrating the System**

Turn on the EG40 to deliver 100 mM KOH with the PeakNet chromatography software. Assess the quality of the blank by measuring the short term noise. In a representative 1-min level portion of the chromatogram, a peak-to-peak measurement should be less than 5 nS. It will take at least 4 h for the system to equilibrate to a stable background conductivity for trace analysis. At times there will be brief increases in conductivity that will minimize upon further operation of the system. It is therefore a good practice to run a system overnight to equilibrate for use the following day.

The sample is loaded with either a syringe or a pressurized reservoir. When using a syringe, take care not to introduce any unwanted contamination by contact of the sample with the syringe. The black rubber plunger in disposable plastic syringes can be a source of significant contamination. To avoid contamination, the syringe should be used to pull the sample into the loop when placed at the waste port as shown in Figure 3. Take care not to introduce bubbles into the loop by pulling too hard. To load sample with a pressurized reservoir, a low-pressure double stack valve regulates the flow of helium with the column valve. Figure 4 illustrates how the system is configured. The AS40 Autosampler's internal components are not compatible with concentrated acid samples; therefore it is not suitable for this type of analysis.

Use commercially available 1000-mg/L ion standards or prepare standards using the information in Table 1. It is recommended to make a 100-mL final volume of 1000-mg/L stock standards in 125-mL high-density polyethylene (HDPE) containers. From this

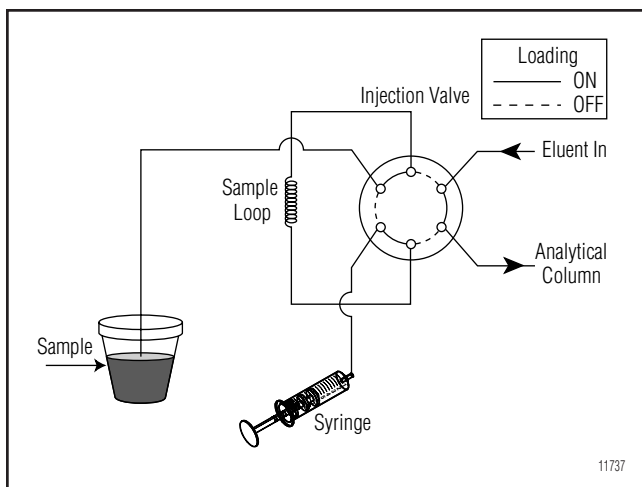

**Figure 3.** Direct injection sample loading by syringe.

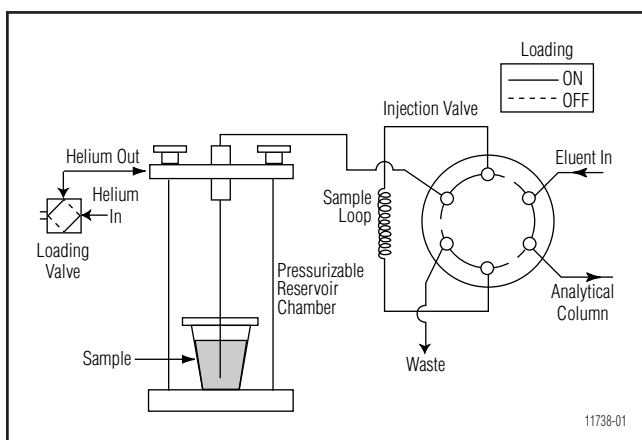

**Figure 4.** Direct injection sample loading by pressure.

stock standard, a 1-mg/L dilute standard is made. Take aliquots from this dilute standard to make working standards in the low- $\mu\text{g/L}$  (ppb) to high-ng/L (ppt) range. Stock standards are stable for at least 1 month when stored in a refrigerator at 4 °C. Dilute stock standards at the low-mg/L (ppm) levels should be prepared fresh weekly. Working standards at the low- $\mu\text{g/L}$  (ppb) range should be made fresh daily.

## DISCUSSION AND RESULTS

An EG40 eluent generator was used to produce high-purity potassium hydroxide (KOH) eluent for this analysis.<sup>3,4</sup> The current applied by a programmable current source determines the concentration of the

KOH. A KOH cartridge in the EG40 contains  $\text{K}^+$  ion electrolyte solution and a KOH generation chamber connected by a cation-exchange connector. The EG40 can generate eluents that are free of carbonate contamination and therefore have lower background conductivity. These features enable the delivery of hydroxide eluent that is low in anionic contamination.

The columns and suppressor used in this method are in the microbore format (2 mm). Microbore chromatography yields a fourfold enhancement in sensitivity compared to separation of the same injection volume in the 4-mm standard bore format. This results in faster sample loading and makes it ideal for limited sample volumes. The slower flow rates result in reduced mobile phase consumption. Use of the EG40 further enhances stable performance by delivering reproducible eluents. The external water mode or gas-assisted recycle mode was chosen over the recycle mode for supplying regen to the ASRS because these modes are more effective at reducing detector noise. A DS3 Detection Stabilizer minimizes the effects of cell drift and temperature fluctuations.

Conditions for the AS15 have been optimized for this application. Nitrate elutes before phosphate when using 33 mM potassium hydroxide. When the concentration is increased to 48 mM potassium hydroxide, the elution order changes so that nitrate elutes last (Figure 5). The method steps to 100 mM KOH for 20 min to elute any residual nitrate left in the column when eluting samples containing high concentrations of nitrate. For the last 20 min of the method the eluent concentration returns to 48 mM KOH to equilibrate the column for the next injection.

Figure 6 shows an analysis for 0.7% (v/v) nitric acid. The sample was prepared by diluting semiconductor grade 70% (w/w) nitric acid to 0.7% (v/v) with deionized water. The large nitrate matrix is well separated from the anions of interest. An injection volume of 1  $\mu\text{L}$  of 0.7% nitric acid minimizes the amount of nitrate loaded onto the column set while maximizing the amount of contaminant ions. A trace amount of chloride was detected in this sample as shown in the detailed view in Figure 7.



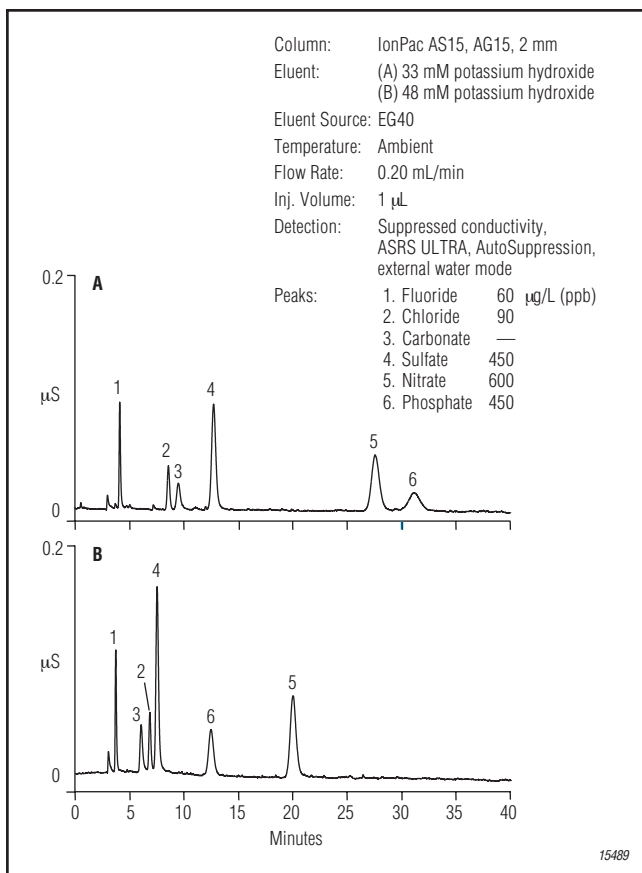

Figure 5. Optimized separation with the IonPac AS15.

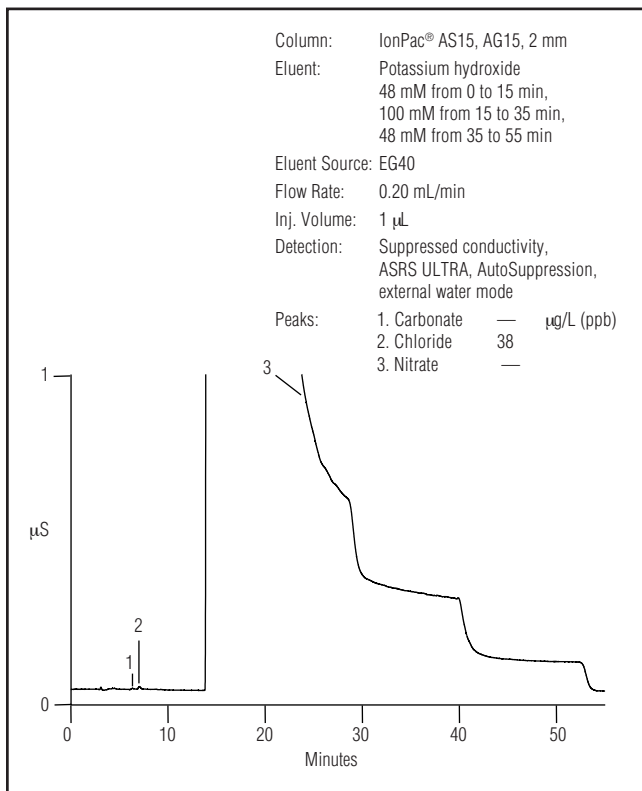

Figure 6. Determination of trace anions in 0.7% nitric acid with an EG40.

## 6 Determination of Trace Anions in High-Nitrate Matrices by Ion Chromatography

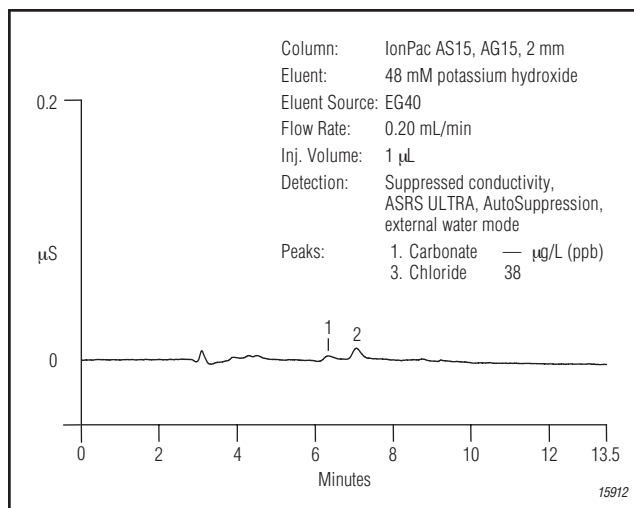

Figure 7. Determination of trace anions in 0.7% nitric acid with an EG40.

A system blank is determined by using deionized water as the sample. The blank establishes baseline anion concentrations from such sources as the sample container and the deionized water used for dilution. Figure 8 shows a representative blank; none of the anions of interest were detected in the blank.

The same sample of 0.7% nitric acid that was analyzed by the EG40 in Figure 7 was also analyzed using sodium hydroxide eluents prepared by the conventional method. Significantly higher amounts of chloride and sulfate as well as an unknown contaminant were detected, as shown in Figure 9. The reason that less anionic contaminants were detected with the EG40 over the bottle system is most likely due to the EG40's ability to produce high-purity eluents.

A spiked standard was prepared by adding aqueous standards of fluoride, chloride, sulfate, and phosphate as shown in Figure 10. To verify proper quantification of analytes in the nitric acid matrix, increasing concentrations of chloride, sulfate, and phosphate were added to the water used to dilute 70% (w/w) nitric acid to 0.7% (v/v). Spikes of 20, 200, and 320 µg/L chloride and 45, 150, 900, and 1500 µg/L sulfate and phosphate yielded coefficients of determination ( $r^2$ ) values greater than 0.99. A spike of 90 µg/L chloride, 450 µg/L sulfate, and 450 µg/L phosphate in 0.7% nitric acid yielded recoveries between 86 and 109%. Table 3 summarizes the spike/recovery data.

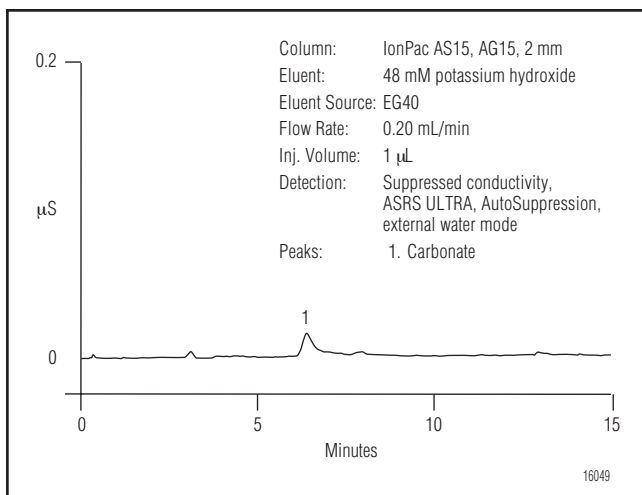

Figure 8. Representative system blank.

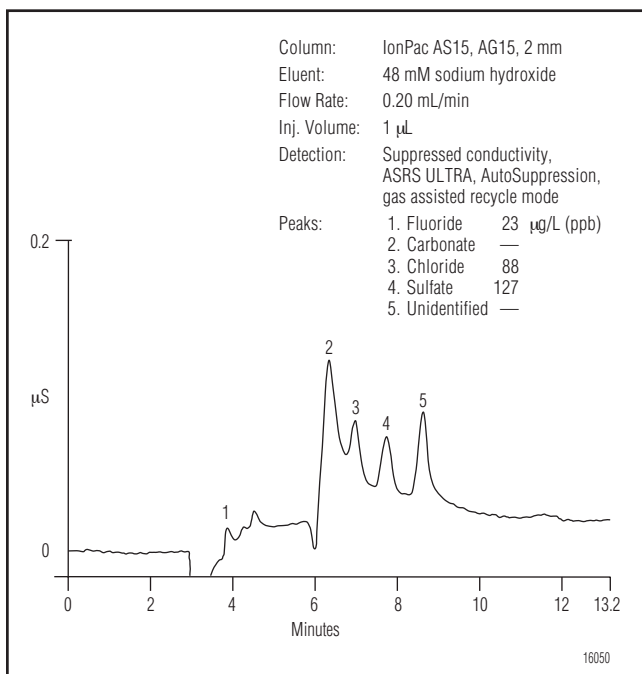

Figure 9. Determination of anions in 0.7% nitric acid with bottle eluent.

Method detection limits (MDLs) were calculated using an ordinary least-squares regression analysis of the calibration data in a matrix of 0.7% nitric acid. A summary of the MDLs and Semiconductor Equipment and Materials International (SEMI) guidelines<sup>5</sup> for the maximum level of chloride, sulfate, and nitrate in 70% nitric acid is shown in Table 4.

If concentrations above 0.7% nitric acid are analyzed with this method, run times increase. The run time increases to over 2 h for an injection of 7.0% nitric acid under these conditions because of the time required to rinse the columns of excess nitrate. It is

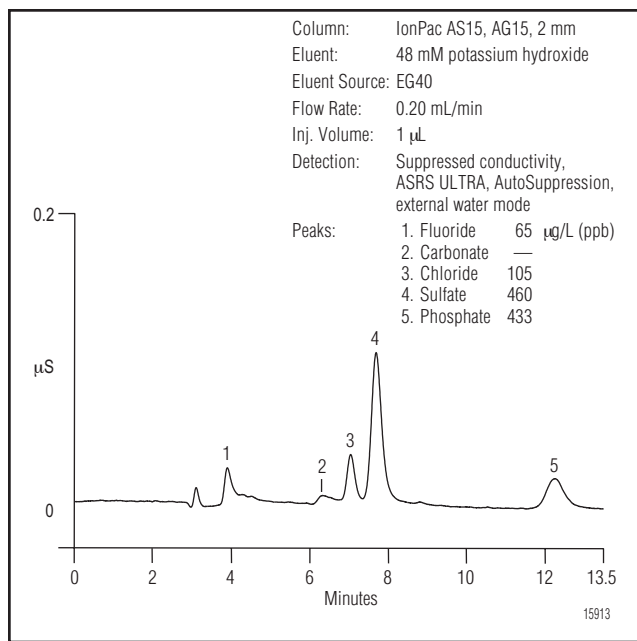

Figure 10. Spiked anions in 0.7% nitric acid.

Table 3. Recovery of Trace Anions in 0.7% Nitric Acid

Anion	Sample Concentration ( $\mu$ g/L)	Standard Addition ( $\mu$ g/L)	Found Minus Blank ( $\mu$ g/L $\pm$ S.D.)	Recovery %
Chloride	32 $\pm$ 3.2	90	77 $\pm$ 1.9	86
Sulfate	—	450	491 $\pm$ 8.7	109
Phosphate	—	450	459 $\pm$ 16	102

For n = 7

Table 4. Method Detection Limits  $\mu$ g/L (ppb) and SEMI<sup>b</sup> Specifications

Anion	MDL <sup>a</sup> 0.7% Nitric Acid	SEMI Specifications 70% Nitric Acid
Chloride	41	50
Sulfate	104	50
Phosphate	120	50

<sup>a</sup> Based on an ordinary least-squares regression analysis

<sup>b</sup> SEMI = Semiconductor Equipment and Materials International

also likely that contaminant anions would not be completely recovered for a 1- $\mu$ L injection of 7% nitric acid. A 1-h run for a 1- $\mu$ L injection of 0.7% nitric acid represents the best compromise for the most sensitivity of the analytes of interest with a reasonable run time.

This method can also be used to determine the anionic contamination of nitrate salts. A solution of 7000 ppm sodium nitrate was analyzed by this method. The sample was prepared by dissolving 0.9597 g of reagent-grade sodium nitrate ( $\text{NaNO}_3$ , formula weight 84.99) in 100 mL of deionized water. An analysis of this sample determined that it contained 38  $\mu\text{g/L}$  chloride and 17  $\mu\text{g/L}$  sulfate (Figure 11).

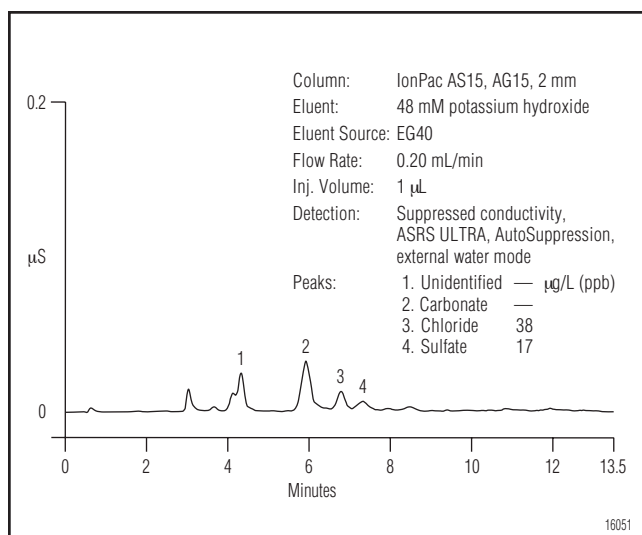

Figure 11. Trace anions in 7000 ppm sodium nitrate.

This application note describes a microbore direct injection method for the determination of trace anions in high-nitrate matrices. An EG40 Eluent Generator was used to prepare high-purity and carbonate-free potassium hydroxide. This improved performance for trace-level analysis over conventional bottle-based hydroxide eluents. Sensitivity to the low-pbb level in 0.7% nitric acid and solutions of nitrate salts up to 7000 ppm was demonstrated with good recovery.

### PRECAUTIONS

Exercise extreme caution when handling concentrated nitric acid. Consult the Material Safety Data Sheet (MSDS) for specific details about protective equipment, reactivity, and health effects..

Use only the highest quality deionized water for the preparation of standards and eluents. Any ionic contamination present in the deionized water will adversely affect results. Teflon containers are recommended for holding the concentrated acid samples for delivery to the sample loop. Containers should be soaked for at least 24 h with 18 M $\Omega$ -cm deionized water prior to use. It is good practice to use all containers only for trace analysis and keep them filled with deionized water when not in use.

The ATCs should be regenerated periodically using the procedure described in the “System Preparation and Setup” section. Monitoring the blank for any significant increase in anionic contamination will indicate when regeneration is necessary. The frequency of regeneration depends on the quality of the deionized water and the usage rate of the instrument.

*Note: The AS40 Autosampler, even with the ULTEM corrosion-resistant cassette guide, is not suitable for this application.*

### REFERENCES

- Kern, J. *Electrochem. Soc.* **1990**, 137, 1887.
- Bader, M. *J. Chem. Educ.* **1980**, 57, 703.
- Liu, Y.; Avdalovic, N.; Pohl, C.; Matt, R.; Dhillon, H.; Kiser, R. *Am. Lab.* **1998**, 30 (22) 48C-58C.
- Liu, Y.; Kaiser, E.; Avdalovic, N. *Microchem. J.* **1999**, 62, 162–173.
- SEMI International Standards: Semiconductor Equipment and Materials International, Mountain View, CA, Chemicals/Reagents Volume, 1997.

### SUPPLIERS

Fisher Scientific, 2000 Park Lane, Pittsburgh, PA 15275-1126 USA, Tel: 1-800-766-7000, [www.fishersci.com](http://www.fishersci.com).

VWR International, 1310 Goshen Parkway, West Chester, PA 19380 USA, Tel :800-932-5000, [www.vwr.com](http://www.vwr.com).



ASRS, AutoSuppression, PeakNet, IonPac, SRS, and EluGen are registered trademarks of Dionex Corporation. Teflon is a registered trademark of E.I. duPont de Nemours & Co.

**Dionex Corporation**  
 1228 Titan Way  
 P.O. Box 3603  
 Sunnyvale, CA  
 94088-3603  
 (408) 737-0700

**Dionex Corporation**  
 Salt Lake City Technical Center  
 1515 West 2200 South, Suite A  
 Salt Lake City, UT  
 84119-1484  
 (801) 972-9292

**Dionex U.S. Regional Offices**  
 Sunnyvale, CA (408) 737-8522  
 Westmont, IL (630) 789-3660  
 Houston, TX (281) 847-5652  
 Atlanta, GA (770) 432-8100  
 Marlton, NJ (856) 596-0609

**Dionex International Subsidiaries**  
 Australia 61 2 9420 5233 Austria (01) 616 51 25 Belgium (32) 3-353 42 94 Canada (905) 844-9650 China (852) 2428 3282  
 Denmark (45) 36 36 90 90 France 01 39 30 01 10 Germany 06126-991-0 Italy (06) 66 51 50 52 Japan (06) 6885-1213  
 The Netherlands (0161) 43 43 03 Switzerland (062) 205 99 66 United Kingdom (01276) 691722  
 \* Designed, developed, and manufactured under an NSAI registered ISO 9001 Quality System.

